

## HF-80-BTs piped to Geothermal Heat Pumps



### Hydronic Buffer Tank Increase System Efficiency

- Eliminate Short Cycling
- Hydraulically Separate the Source from the Distribution System
- Available in 40, 60, 80 and 115 gallons
- Choice of fitting sizes 1 1/4", 1 1/2" or 2"



**Heat-Flo**  
HEATING PRODUCTS

# Hydronic Buffer Tanks

## Application: Geothermal Heat Pumps / Chillers / Low Mass Boilers

The primary application of a buffer tank is to reduce heat pump, chiller, or boiler short cycling. Hydronic buffer tanks are used in systems operating below the design load condition, which is most of the time, or in systems having several low BTU cooling or heating loads calling at different times. This can cause the heat pump or boiler to short cycle, resulting in reduced operating efficiency and shorter equipment life.

The hydronic buffer tanks are built with 4 connections. Two connections can be piped to the heat pump or boiler, and two connections can be piped to the distribution system. If piped correctly, the tank can serve as both a thermal buffer and a hydraulic separator. The heat pump or boiler can be hydraulically decoupled from the distribution system. The tanks are all 316L stainless steel construction with R-12 insulation, and an ABS jacket.

A 3/8" ID thermal well is located mid-tank. Thermistors can be inserted 3" into the well, or the well will accept the Honeywell L4006A controls.

Buffer tanks are available in 40, 60, 80 and 115 gallon capacities.

Specify 1 1/4", 1 1/2", or 2" connections.

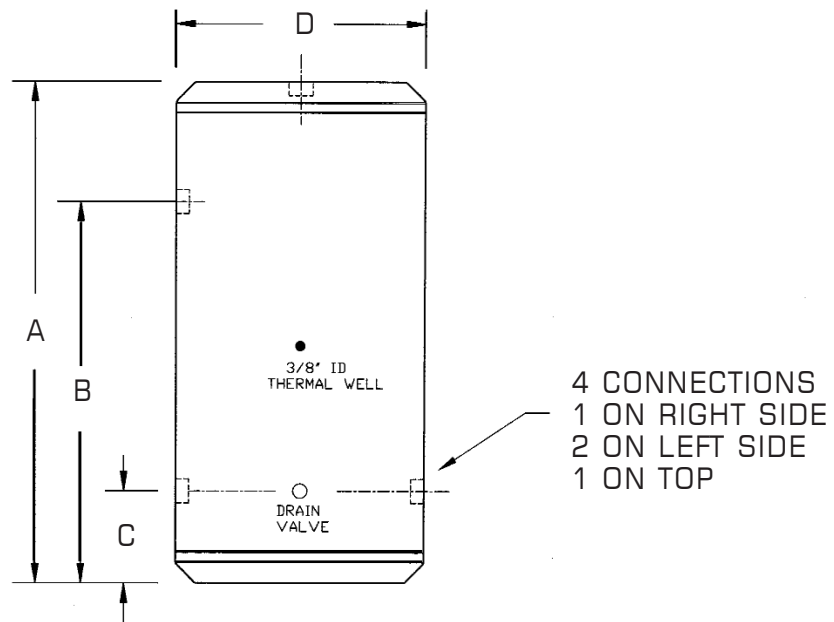

4 CONNECTIONS  
1 ON RIGHT SIDE  
2 ON LEFT SIDE  
1 ON TOP

Model	Volume (gal.)	A Height	B	C	D Diameter	Connections (NPT)	Max. Working Pressure (psi)	Approx. Ship Wt. (lbs.)
HF40-BT-XX	40	42.0	29.0	9.0	22.5	Specify	60	87
HF60-BT-XX	60	42.0	29.5	9.5	26.5	1 1/4", 1 1/2"	60	115
HF80-BT-XX	80	52.0	39.5	9.5	26.5	or 2" NPT	60	125
HF115-BT-XX	115	72.0	59.5	9.5	26.5		60	160

All dimensions in inches  
-XX denotes connection size. Specify 1 1/4", 1 1/2", or 2" NPT.

# Buffer Tank Sizing - Calculating Capacity

The Heat-Flo buffer tanks are a simple, cost effective way to improve overall system operating efficiency by reducing unnecessary equipment short cycling. The recommended capacity or volume of a buffer tank is based on four variables.

1. The duration of the heating or cooling source "on time". (minutes)

The desired length of "on time" for each run cycle depends on the type of equipment used. Heat pump and chiller manufacturers typically recommend a minimum of 5 to 10 minutes on time, and boiler manufacturers may recommend a minimum of 10 minutes "on time". Check with your equipment manufacturer. Generally, the longer the on time, the higher the overall operating efficiency.

2. The minimum rate of heat input. (BTU/HR)  
This is based on the heat pump or chiller output, or the boiler output at the minimum firing rate if the boiler has a variable input system that ramps input down as the demand decreases.
3. The minimum system load (BTU/HR)  
This is the demand placed on the system with the smallest zone calling for heat.
4. The allowable tank temperature rise. (deg. F)  
This varies depending on the type of heating or cooling system used, and on the design of the distribution system. Chillers may require a tight, (6 deg. F), differential to assure good dehumidification and prevent freezing, heat pumps may require a 10 deg. F differential to maintain a high COP, and boilers with hydronic heating distribution systems may require a differential anywhere between 10 to 40 deg. F depending on the application.

The following formula determines the tank volume:

$$V = \frac{T \times (Q_{\text{heat input}} - Q_{\text{min. heat load}})}{\text{Tank temp. rise} \times 500}$$

V = Buffer tank volume (gallons)  
T = desired heat source "on cycle" (min.)  
Q heat source = heat source output (BTU/HR)  
Q min. heat load = heat output to minimum load  
Tank temp rise (deg.F)

Water to Water Heat Pump Example: Town and Country Mechanical wants a minimum heat pump on time of 10 minutes. The heat pump output is 46,500 BTU/HR. The smallest zone is a 7,000 BTU/HR bathroom. The allowable temperature differential is 90 to 100 deg. F for the radiant heating zones.

$$V = \frac{10 \times (46,500 - 7,000)}{(100-90) \times 500} = 79.0 \text{ Gallons minimum volume. Choose the HF-80BT buffer tank.}$$

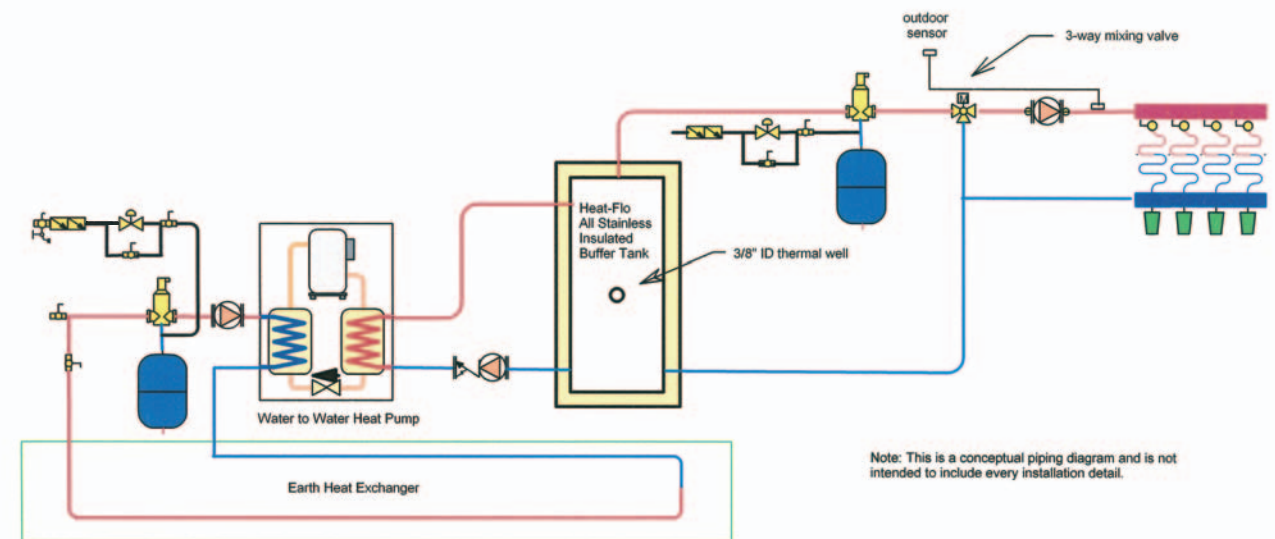

Hydronic Buffer Tank applied to Water source heat pump application