

# INSTALLATION, OPERATING AND SERVICE INSTRUCTIONS

## HEAT-FLO INDIRECT-FIRED WATER HEATERS

### SOLAR HOT WATER STORAGE TANKS SINGLE COIL OR DUAL COILS WITH OR WITHOUT ELECTRIC BACKUP

MODELS 60D, 60E, 60DE  
80D, 80E, 80DE  
115D, 115E, 115DE



#### FOR SINGLE WATER HEATER INSTALLATIONS

For service or repairs to the water heater, call your heating contractor. Your water heater has been manufactured to provide years of service. In order to insure proper service, the following information is provided to assist in enabling the installation, operation, and maintenance of this water heater. When the installation is completed, keep this manual with the water heater.

**Heat-Flo Inc.**  
**15 Megan Court**  
**Uxbridge, MA 01569**

**Bulletin IO-SOLAR-090111**

## **I. General Information**

### **IMPORTANT INFORMATION – READ CAREFULLY**

NOTE: The equipment shall be installed in accordance with those installation regulations required in the area where the installation is to be made. These regulations shall be carefully followed in all cases. Authorities having jurisdiction shall be consulted before the installations are made.

All wiring on water heaters shall be in accordance with the National Electrical Code and/or local regulations.

#### **WARNING**

Improper installation, adjustment, alteration, service or maintenance can cause property damage, personal injury, or loss of life. Read and understand the entire manual before attempting installation, start-up, operation, or service. Installation and service must be performed only by an experienced, skilled installer or service agency.

This water heater contains very hot water under high pressure. Do not unscrew any pipe fittings or attempt to disconnect any components of this water heater without positively assuring that the water is cool and has no pressure. Always wear protective clothing and equipment when installing, starting up or servicing this water heater to prevent scalding injuries. Do not rely on the pressure and temperature gauges to determine the temperature and pressure of the water heater. This water heater contains components that become very hot when the boiler is operating. Do not touch any components unless they are cool.

Failure to follow all instructions in the proper order can cause personal injury or death. Read all instructions, including all those contained in component manufacturers' manuals before installing, starting up, operating, maintaining, or servicing the water heater.

#### **CAUTION**

To reduce the risk of excessive pressures and temperatures in this water heater, install temperature and pressure protective equipment required by local codes but no less than a combination temperature relief valve certified by a nationally recognized testing laboratory that maintains periodic inspection of production of listed equipment or materials, as meeting the requirements for Relief Valves and Automatic Shutoff Devices for Hot Water Supply Systems, ANSI Z21.22-latest edition. This valve must be marked with a maximum set pressure not to exceed the marked working pressure of the water heater. Install the valve into an opening provide and marked for this purpose in the water heater, and orient it or provide tubing so that any discharge from the valve will exit only within 6 inches above, or at any distance below, the structural floor, and cannot contact any live electrical part. The discharge opening must not be blocked or reduced in size under any circumstances.

The heat transfer medium must be water or other non-toxic fluid having a toxicity rating or class of 1, as listed in clinical Toxicology of Commercial Products, latest edition.

The pressure of the heat transfer medium must be limited to a maximum of 30 psig by an approved safety or relief valve.

#### **DANGER**

DO NOT store or use gasoline or other flammable vapors or liquids in the vicinity of this or any other appliance. If you smell gas vapors, DO NOT try to operate any appliance - DO NOT touch any electrical switch or use any phone in the building. Immediately, call the gas supplier from a remote located phone. Follow the gas supplier's instructions or if the supplier is unavailable, contact the fire department.

## **IMPORTANT SAFETY INSTRUCTIONS**

WARNING – When using electrical appliances, basic safety precautions to reduce the risk of fire, electric shock, or injury to persons should be followed, including:

READ ALL INSTRUCTIONS BEFORE USING THIS WATER HEATER.

1. This water heater must be grounded. Connect only to properly grounded outlet. See “GROUNDING INSTRUCTIONS” found in Section IV.
2. Install or locate this water heater only in accordance with the provided installation instructions
3. Use this water heater only for its intended use as described in this manual.
4. Do not use an extension cord set with this water heater. If no receptacle is available adjacent to the water heater, contact a qualified electrician to have one properly installed.
5. As with any appliance, close supervision is necessary when used by children.
6. Do not operate this water heater if it has a damaged cord or plug, if it is not working properly, or if it has been damaged or dropped.
7. This water heater should be serviced only by qualified personnel. Contact nearest authorized service facility for examination, repair, or adjustment.

**SAVE THESE INSTRUCTIONS**

**Table 1 Dimensions and Capacities**

Model	Storage Volume	Top Coil Heating Surface	Bottom Coil Heating Surface	Dimensions (inches)		Pipe Connections	Max. Working Pressure	Approx. Shipping Wt. - Lbs.
	(Gals.)	Sq. Ft.	Sq. Ft.	Ht.	Dia.		(psi)	
<b>Single Coil - No Electric Backup</b>								
HF-115	115	-	8.9	74.0	28.0	1" NPT	150	175
HF-80	80	-	8.0	56.0	28.0	1" NPT	150	140
HF-60	60	-	8.3	62.0	23.5	1" NPT	150	125
<b>Single Coil with 3500 watt Electric Backup</b>								
HF-115-E	115	-	8.9	74.0	28.0	1" NPT	150	180
HF-80-E	80	-	8.0	56.0	28.0	1" NPT	150	145
HF-60-E	60	-	8.3	62.0	23.5	1" NPT	150	135
<b>Dual Coil - No Electric Backup</b>								
HF-115-D	115	7.4	8.9	74.0	28.0	1" NPT	150	205
HF-80-D	80	7.4	8.0	56.0	28.0	1" NPT	150	175
HF-60-D	60	7.4	8.3	62.0	23.5	1" NPT	150	165
<b>Dual Coil with 3500 watt Electric Backup</b>								
HF-115-DE	115	7.4	8.9	74.0	28.0	1" NPT	150	215
HF-80-DE	80	7.4	8.0	56.0	28.0	1" NPT	150	185
HF-60-DE	60	7.4	8.3	62.0	23.5	1" NPT	150	175
<b>Storage Only - No Coil, No Electric Backup</b>								
HF-115-ST	115	-	no coil	74.0	28.0	1" NPT	150	170
HF-80-ST	80	-	storage	56.0	28.0	1" NPT	150	130
HF-60-ST	60	-	only	62.0	23.5	1" NPT	150	115

### SINGLE COIL UNITS

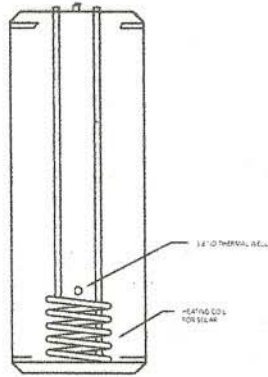
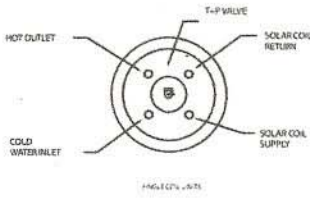

### DUAL COIL UNITS

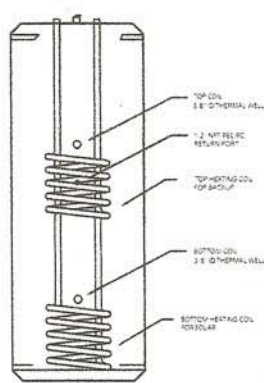
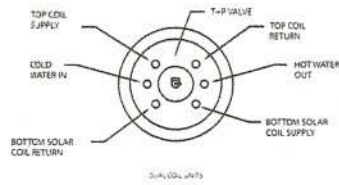

### STORAGE UNITS

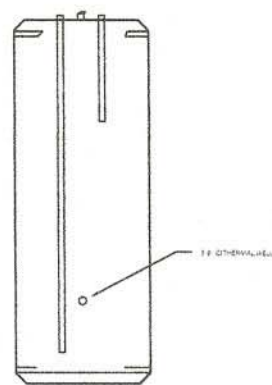
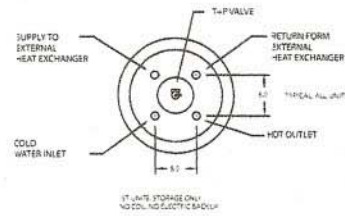

### ELECTRIC BACKUP UNITS

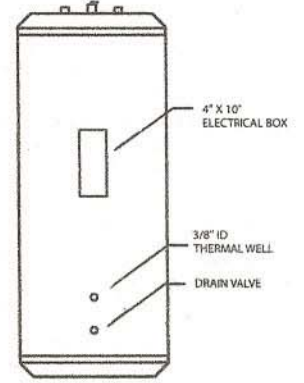
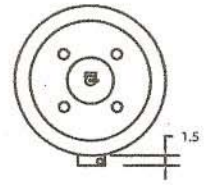

Heat exchanger coil outputs				
Model	Max. Recovery (gal/hr.) Top Coil	Max. Recovery (gal/hr.) Bottom Coil	Water Flow Through Coil (gal./min.)	Pressure Drop Through Coil (Ft. Water)
115 Gal. Units	190	214	10.0	3.9
80 Gal. Units	180	214	10.0	3.6
60 Gal. Units	185	214	10.0	3.5

Note: All Ratings are based on 180 degree F boiler water supply and 50 degree F cold Water inlet. In the interest of continuous improvement, specifications are subject to change without notice.

For all units with 3500 watt Electric Backup				
Model	First Hour Rating (gal/hr.)		Continuous Rating (gal/hr.)	
	140 F	115 F	140 F	115 F
115 Gal. Units	73.9	80.0	15.9	22.0
80 Gal. Units	55.9	62.0	15.9	22.0
60 Gal. Units	45.9	52.0	15.9	22.0



Conforms to UL STD 174  
 Certified to CAN/CSA STD C22.2 No.110-94

## Table of Contents

Section I - General Information Dimensions, Weights, Ratings and Capacities	Section V - Operation Section VI - Maintenance
Section II - Pre- Installation	Section VII - Troubleshooting
Section III - Piping	Section VIII – Water Heater Selection Data
Section IV - Electrical	

## II. Pre-installation Considerations

Inspect shipment carefully for signs of damage. All equipment is carefully inspected and packed. Heat-Flo's responsibility ceases upon delivery of the water heater to the carrier in good condition. Any claims for damage or shortage, must be filed immediately against the carrier by the consignee. No claims for variances or shortages will be allowed by the Manufacturer, unless they are presented within sixty days after receipt of the equipment.

Installation must conform to the requirements of the authority having jurisdiction. In the absence of such requirements, installation must conform to the National Plumbing Code and the National Electrical Code ANSI/NFPA No. 70, current edition.

### IMPORTANT CONSIDERATIONS BEFORE INSTALLATION

#### 1. Water heater sizing.

Choose the water heater model based on the expected water usage for the given site. The average residence with one shower or more will require a Model 40 or larger. The Model 30 should only be considered for residences with minimal water demand, or for commercial applications without showers.

Factors that increase water demand dramatically include high flow shower heads, hot tubs, and the use of more than one shower at a time. Increase the tank size if these factors are present. Consult ASHRAE sizing guides and other references.

Dimensions, weights, ratings, and capacities are outlined in Tables 1 and 2.

#### 2. Boiler sizing.

The water heater will provide the rated performance only if it is used with a boiler with a heating capacity of at least as much as the capacity ratings in Table 2. If the boiler has less capacity, the water heating output will be reduced. To determine performance with other boiler outputs, refer to the expanded capacity tables in the Appendix.

#### 3. Circulator sizing.

Refer to Table 2 for the minimum flow through the water heater coil and the pressure drop at minimum flow. Calculate the pressure drop across all piping and fittings connected to the water heater zone. Be sure to include all zone valves, check valves, and shut-off valves. It is

recommended that the water heater zone be piped with 1” pipe around the entire loop on typical residential sites.

## B. System Zone Control

The water heater must be installed as a separate zone from the space heating system. The water heating zone’s piping and circulator must be sized for the minimum flow rate with all the zones in use and a maximum flow with only the water heater in use. This is the reason that the best method of zone control is with circulators.

The three most common systems are:

1. **Zone Circulators-** The space heating zones use a circulator for each zone, and the water heater is controlled with an additional circulator.
2. **Hybrid System-** The space heating zones use zone valves for each zone, and the water heater is controlled with an additional circulator.
3. **Zone Valves –** The space heating zones use zone valves for each zone, and the water heater is controlled with an additional zone valve. Select a valve with a low pressure drop, and assure minimum flow with adequate pipe sizing.

## C. Priority or Non-Priority for Hot Water

1. **Option 1 – Priority.** The demand for space heating is interrupted until the hot water demand is satisfied. This option provides the maximum delivery of hot water.

Priority is recommended when:

- a. The boiler output is less than 100,000 Btu per hour, or
- b. The boiler output required to satisfy the hot water demand is more than 50% of the boiler output needed to satisfy the space heating demand, or
- c. When an interruption in space heating can be tolerated during long domestic hot water draws.

In most cases the delay in space heating will not be noticed because of the rapid recovery of the water heater. It must be recognized however that certain water heater malfunctions, such as a failed thermostat or circulator, could delay space heating indefinitely.

2. **Option 2 – Non-Priority.** The boiler output is divided between space heating and water heating. Heating of domestic hot water can be reduced during simultaneous space and water heating demands. The amount of reduction depends on the boiler output, the number of space heating zones calling, and the amount of boiler water flow split between the space heating and zones and the water heater zone.

## D. Locating the water heater.

The water heater should be located in an area where water leakage from the tank or connections will not result in damage to areas adjacent to the water heater or to lower floors of the structure. When such a location can not be avoided, a suitable drain pan must be installed under the water heater, and the drain pan must be connected to a drain.

The water heater should be installed as close to the boiler as is practical for easy access for service. The unit is designed for installation on combustible flooring and in alcoves, closets, etc.

The minimum clearances from combustible surfaces are:

Bottom-----0”  
Left, right, and rear sides -- 1”  
Front-----1”  
Top-----6”

The minimum clearances for service are:

Bottom-----0”  
Left, right, and rear sides -- 3”  
Front-----30”  
Top-----6”

#### E. Additional recommended components

1. Shut-off valves. Allows the isolation of the water heater from the boiler system during service.
2. Unions. Allows for easy locating or removal.
3. Vacuum breaker. Protects the water heater from collapse if a hot tank is valved off to service other components in the system.
4. Thermal expansion tank. If the water heater is installed in a closed water supply system, such as a system having a back flow preventer in the cold water supply line, the installation of a thermal expansion tank is required.

#### F. Removing the Existing Domestic Water Heating System

1. External Tankless Heater- Disconnect all lines to the boiler and plug the boiler fittings. Disconnect the external heater from the boiler piping, and the domestic piping systems.
2. Internal Tankless Heaters- Disconnect the domestic piping. Do not plug the cold water or the hot water fittings in the internal tankless coil. Leave the coil in the boiler with the cold and hot water fittings open to prevent pressure build-up in the coil.

#### G. Water Quality

Improper water quality will reduce the expected life of the water heater. Hard water, sediment, high or low Ph, and high levels of chlorides in the domestic water should be avoided. Sediment and hard water will eventually coat the heating coil inside the water heater and reduce the rate of hot water production and may, eventually cause a failure. High or low Ph and/or high chloride concentrations will cause corrosion and eventually failure. A filter is strongly recommended where sediment is present in the water. A water softening system is recommended for areas with hard water.

In an area where the water quality is not known, a water quality test should be performed.

#### WARNING:

Do not operate the Heat-Flo water heaters in areas where the Ph is above 8.0 or below 6.0, and/or with chloride concentrations greater than 80 parts per million (ppm). Heat-Flo's standard warranty does not cover problems caused by improper water Ph or excessive levels of chlorides.

### III. Piping

#### A. Domestic water piping. See Figure 1.

1. Drain the domestic water system.  
Shut off the cold water supply at the main shutoff valve.  
Open one or more faucets to relieve the pressure. Open the system drain, leaving the faucets open.
2. Position the water heater in the final location.
3. Connect the cold water supply piping.  
Install piping onto cold inlet connection.

Connect to cold water supply connection using a union, a heat trap, a shut-off valve, an expansion tank (where required), a back flow preventer (where required), and a filter (recommended to prevent sediment buildup).

4. Connect the domestic hot water piping.  
Install piping on to hot water supply connection using a union, a heat trap, a vacuum breaker, and a shut-off valve.

Pipe the relief valve discharge so that the discharge from the valve will exit only within 6 inches above, or at any distance below, the structural floor, and cannot contact any live electrical part. The discharge opening must not be blocked or reduced in size under any circumstances.

5. Fill the water heater tank.  
Open all faucets to allow air to purge from the tank and piping. Remove screens on faucets.  
Open domestic hot water shut-off valve.  
Open cold water inlet shut-off valve.  
Purge all of the air from the domestic water system. Allow water to run so the tank is completely purged of any debris. Run the water long enough to change at least five tank volume changes. Close all faucets. Reinstall all of the screens in the faucets.  
Check the system for leaks. Repair as required.

#### B. Water boiler piping. See Figures 2 and 3.

1. Determine where the boiler, the space heating, and the water heater connections should be made based on the type of piping system that is either in place, or is to be installed for a new hydronic system installation. See Figure 2, Boiler Water Piping with Zone Circulators, and Figure 3, Boiler Water Piping with Zone Valves.
2. It is recommended that 1" pipe and 1" zone valves be used on the water heater zone.

#### Zone Circulator System

For space heating systems that use Zone Circulators, refer to Figure 2. The water heater connection labeled "BOILER SUPPLY" should be piped to the boiler supply piping after the

air purger and before the space heating takeoffs. Mount the water heater circulator as close as possible to the water heater, and make sure the flow arrow points toward the water heater. The use of shut-off valves is recommended for future service convenience.

The water heater connection labeled “BOILER RETURN” should be piped to the boiler return piping as close to the boiler as possible and after any flow control or check valves in the space heating return piping. The use of a union and a shut-off valve is recommended. The use of a check valve is required to prevent back flow through the water heater during operation of the space heating system.

### **Zone Valve System**

For a space heating system that uses Zone Valves, refer to Figure 3. The water heater connection labeled “BOILER SUPPLY” should be piped to the boiler supply piping after the air purger and before the space heating circulator. Mount the water heater circulator as close as possible to the water heater, and make sure the flow arrow points toward the water heater. The use of a shut-off valve is recommended for future service convenience.

The water heater connection labeled “BOILER RETURN” should be piped to the boiler return piping as close to the boiler as possible and after any flow control or check valves in the space heating return piping. The use of a union and a shut-off valve is recommended. The use of a check valve is required to prevent back flow through the water heater during operation of the space heating system.

# Indirect Piping

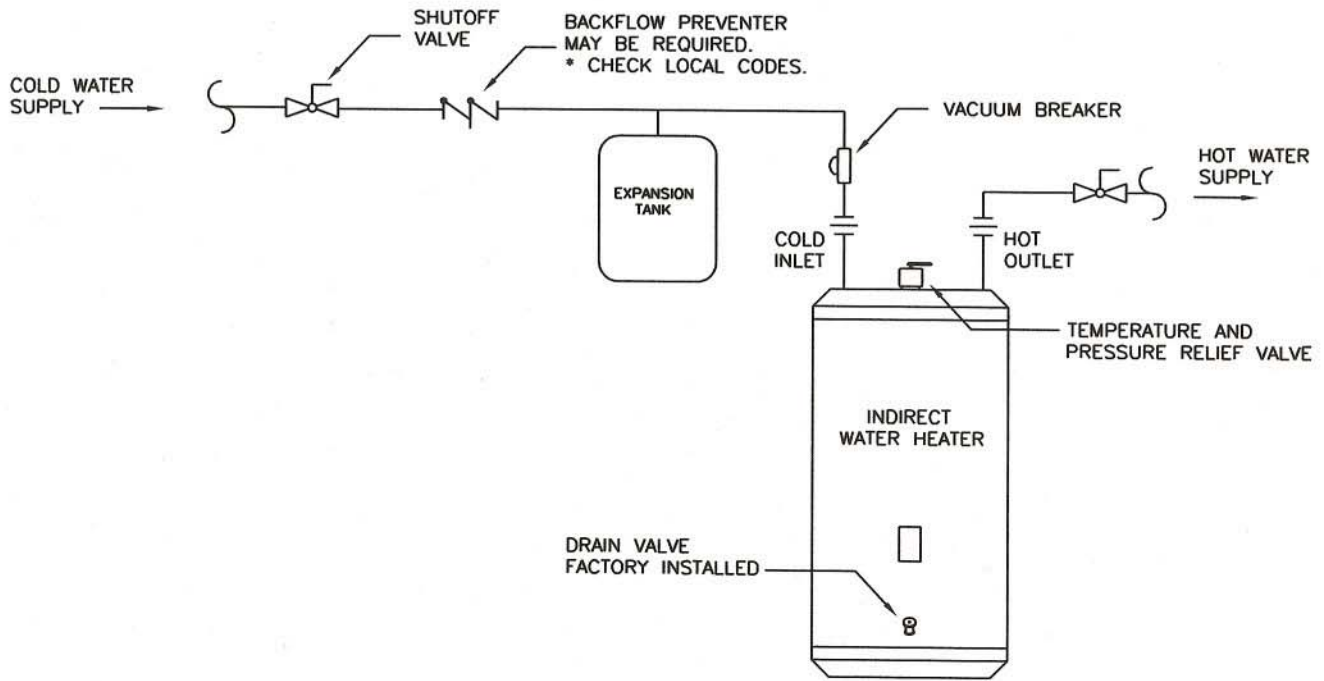

FIGURE 1  
DOMESTIC WATER PIPING

NOTE: SEE LOCAL CODE REQUIREMENTS.  
BACKFLOW PREVENTER CONFORMING TO CMR 248,  
MASS. STATE CODE REQUIRED IN MASSACHUSETTS.

# Indirect Piping

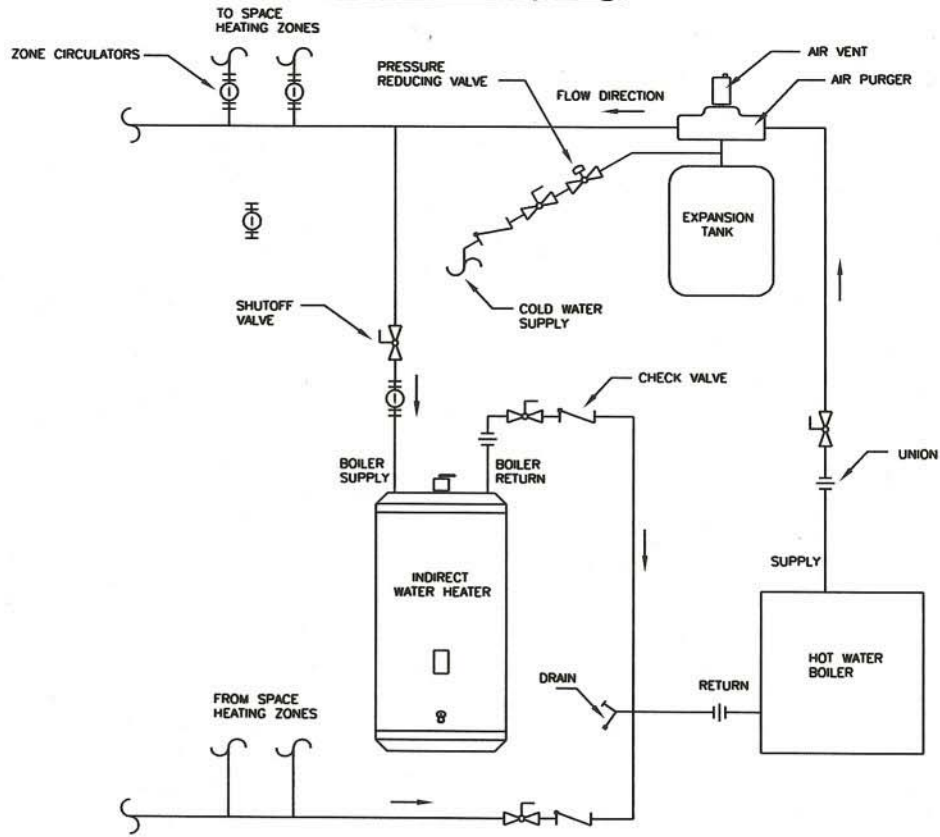

FIGURE 2 - BOILER WATER PIPING WITH ZONE CIRCULATORS

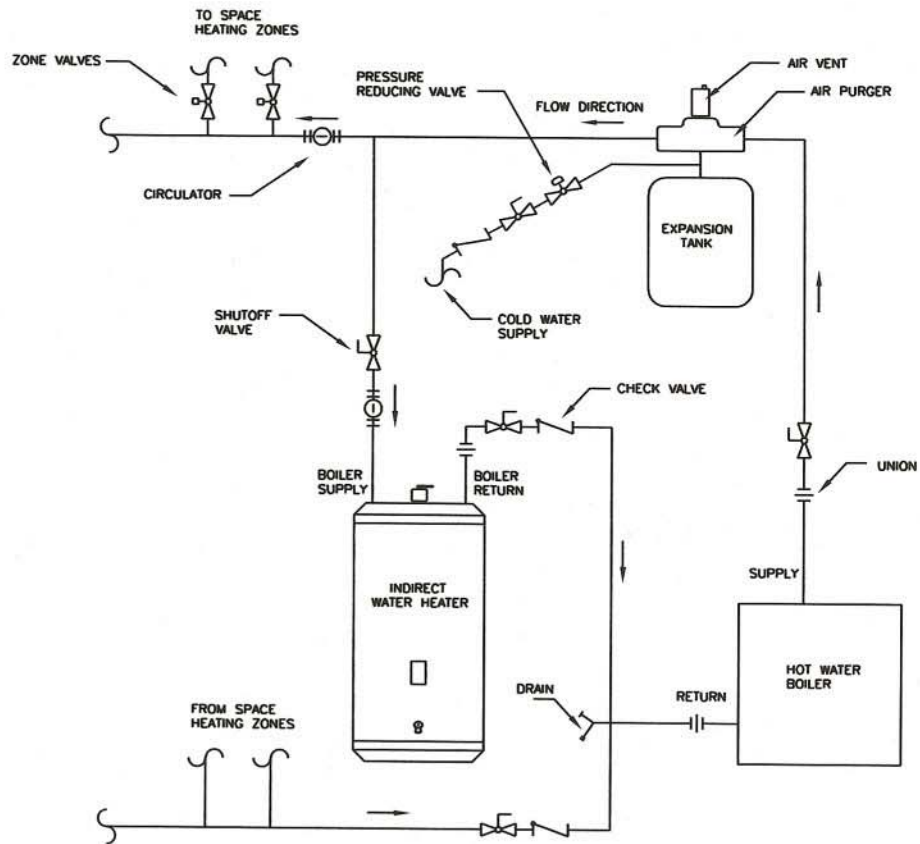

FIGURE 3 - BOILER WATER PIPING WITH ZONE VALVES

# Solar Piping

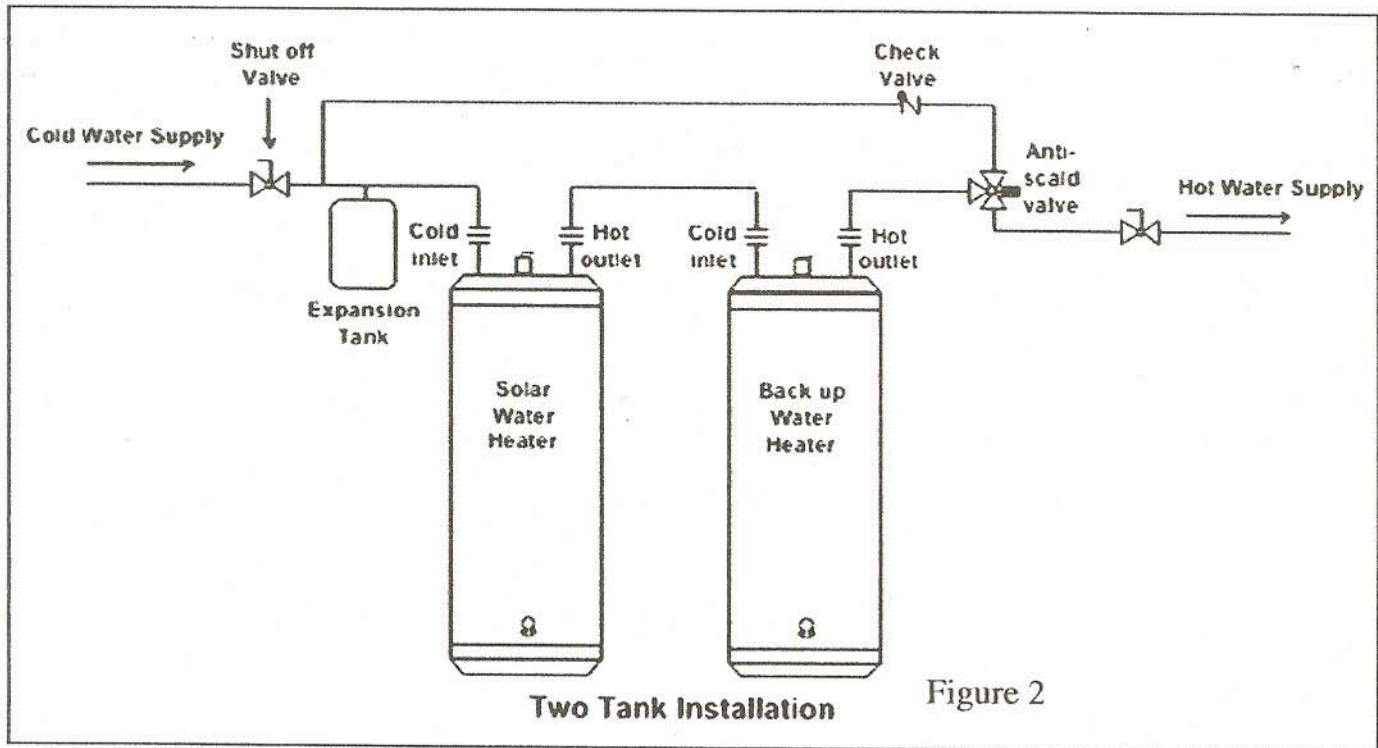
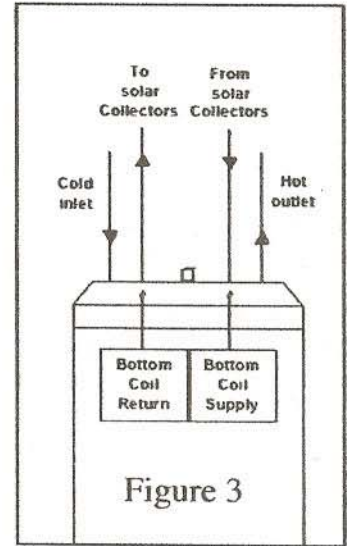
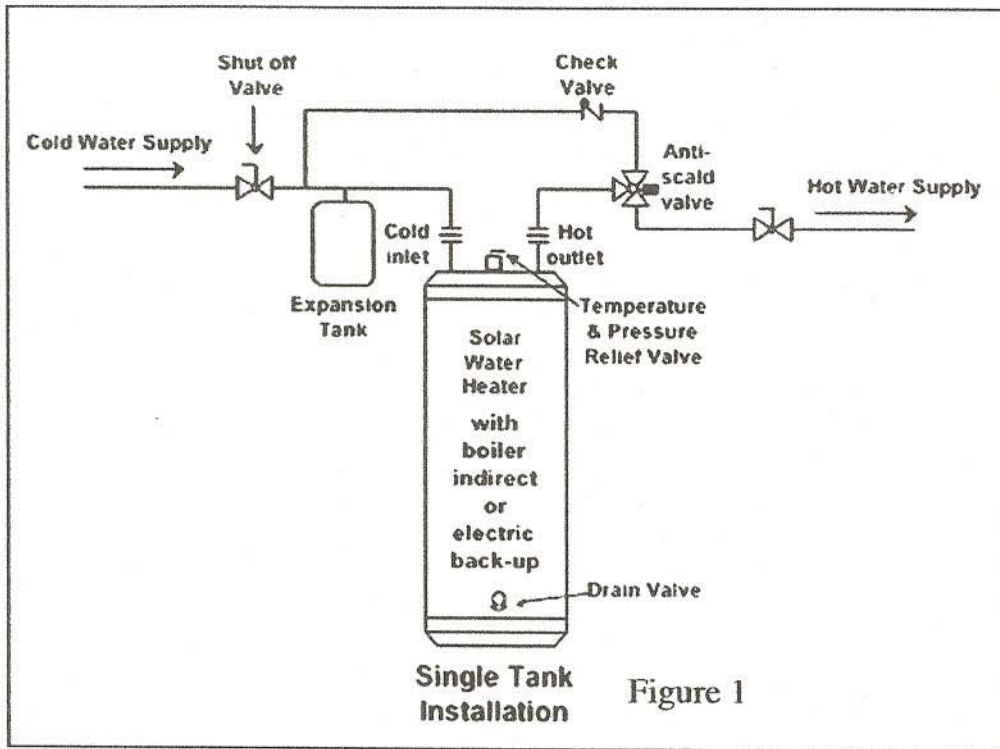
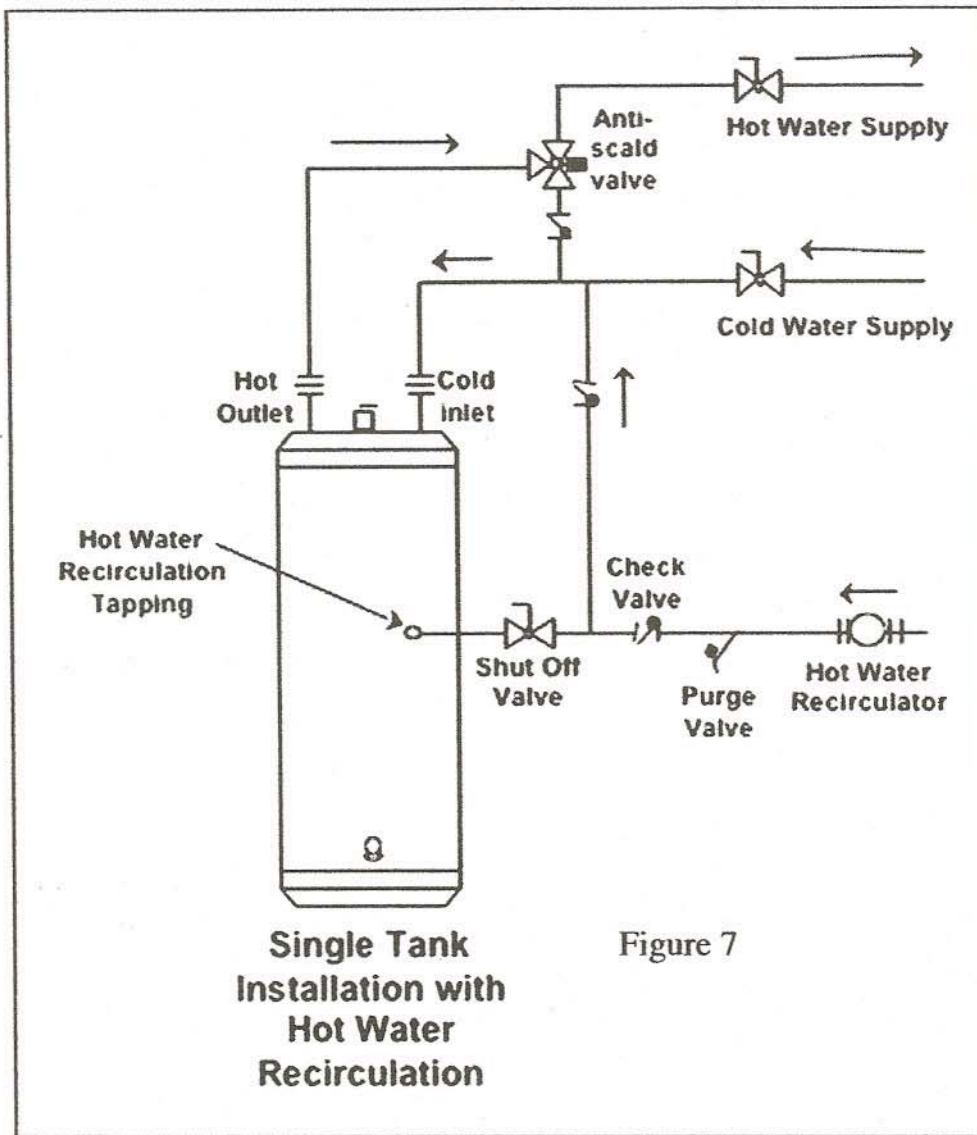

Figure 2

# Solar Piping



## Section VI Hot Water Recirculation

### Hot Water Recirculation for Solar Hot Water Storage Tanks

Hot Water recirculation is for the continuous circulation of hot water for instant hot water at the hot water faucets. With the solar tanks tapplings are provided for the hot water recirculation return at the distance mid-height at the side of the tank. See figure 7. The location of the tapping will not allow for the mixing of back-up heated hot water (boiler indirect or electric element) into the lower solar heated section of the tank.

When an anti-scald device is installed it is critical to feed the cold supply of the mixing valve with the return of recirculated hot water. This is important to keep the hot water recirculation loop operating through the mixing valve even if the tank temperatures are above the mixing valve setting. Otherwise the mixing valve will not allow the flow of hot water through it and disable the recirculation loop of hot water.

# Indirect Wiring

## IV. Electrical

1. Install electric wiring and grounding in accordance with the National Electrical code and local regulations.
2. All water heaters are supplied with a thermostat.
3. Refer to schematics 1, 2 and 3 for separate circulator wiring.  
Refer to schematics 4, 5 and 6 for zone valve wiring.  
Reference should be made to the Installation Manual for the boiler as well.

## V. Operation

### **Startup**

After the water heater has been plumbed and wired, and the boiler water piping is purged of air, the water heater is ready to be started.

1. Follow the boiler installation instructions to place the boiler in operation.
2. The tank thermostat is factory pre-set to 125 degrees F and will call for heat if the water in the tank is lower than 125.
3. On a call for heat, the tank thermostat contacts close to start the water heater zone circulator and the boiler.
4. After the tank has reached the temperature setting, the tank thermostat opens and de-energizes the circulator and the boiler. If there is a call for space heating, the boiler will continue to run until the room thermostats are satisfied.

### **Temperature Adjustment**

The tank thermostat controls the maximum water temperature in the water heater. If it is set too high, the resulting hot water can cause painful scalding with possible serious and permanent injury. The temperature at which this occurs varies with a person's age, and the length of time in contact with the hot water. The slower response time of infants, older, or handicapped people increases the hazard for them.

It is recommended that the thermostat be set for the lowest possible temperature that satisfies your needs. This will also provide you with the lowest energy consumption and cost.

Check the water temperature at a hot water faucet soon after the tank thermostat has satisfied, and the circulator and the boiler have turned off. Adjust as needed.

Lowering the thermostat setting will not have an immediate effect on the water temperature because the stored water will have to be used and the thermostat must go through the cycle of heating cold water and satisfying at the new, lower temperature. Additional temperature checks should follow the completion of a heating cycle. Further adjustments may be required after you have used the water heater.

# Indirect Wiring

## SEPARATE CIRCULATOR WIRING

Honeywell Relay R4222D1013 with Q633A receptacle

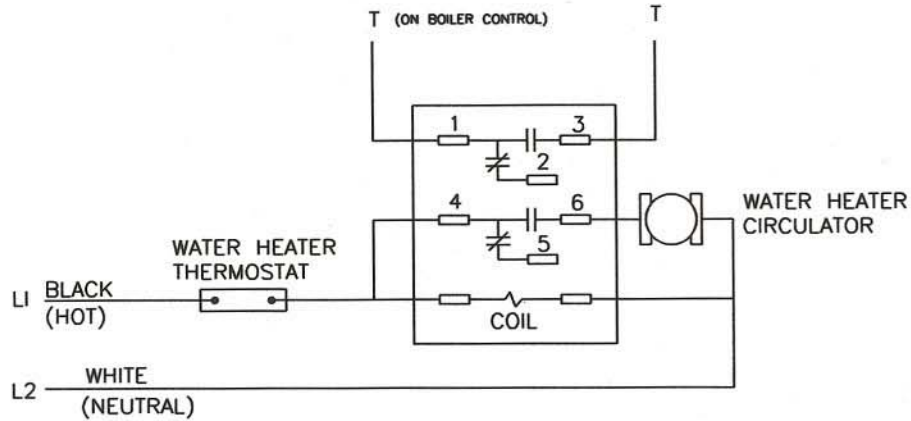

SCHEMATIC 1  
24 VOLT "T-T" WIRING

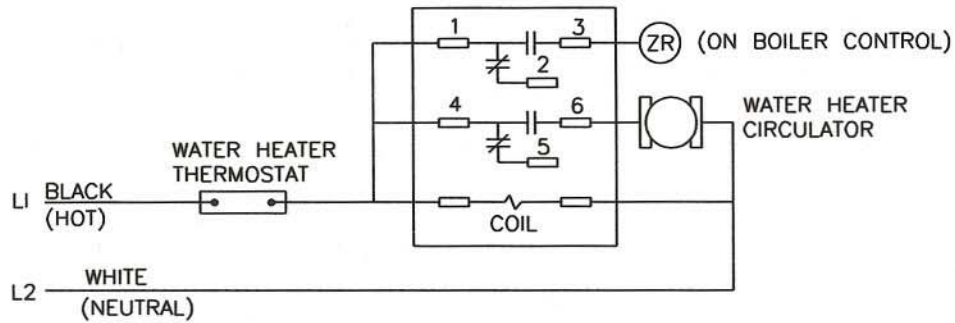

WHEN NO "ZR" TERMINAL IS AVAILABLE  
WIRE TO THE SUPPLY SIDE OF THE HI LIMIT

SCHEMATIC 2  
120 VOLT - ZR TERMINAL

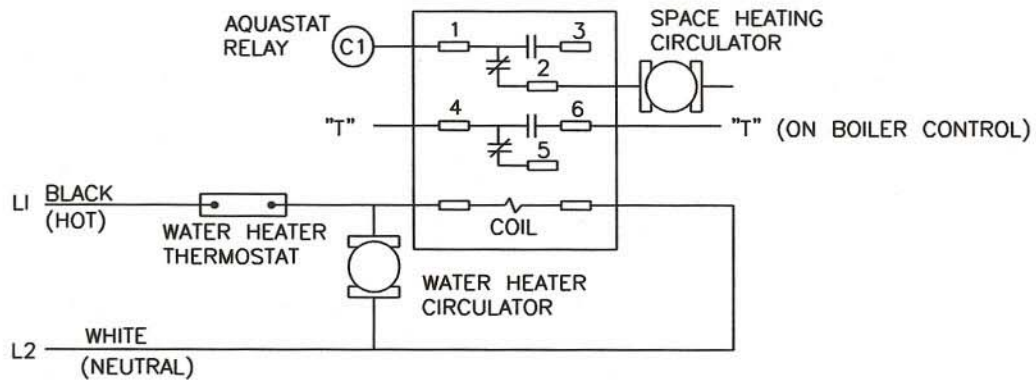

SCHEMATIC 3  
PRIORITY WITH CIRCULATORS

# Indirect Wiring

## ZONE VALVE WIRING

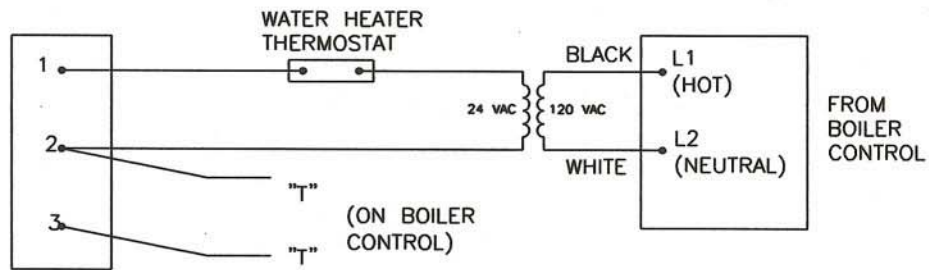

SCHEMATIC 4  
3-WIRE ZONE VALVE

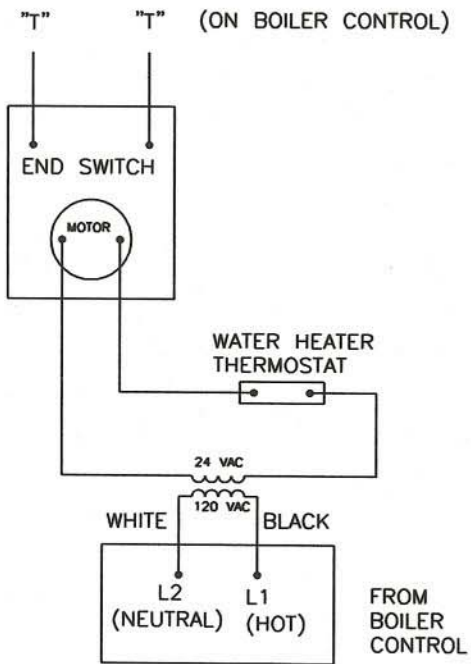

SCHEMATIC 5  
4-WIRE ZONE VALVE WITH 24 VOLT MOTOR

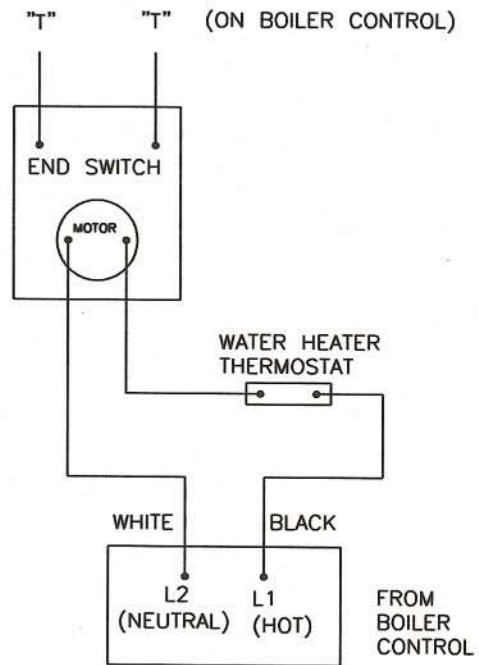

SCHEMATIC 6  
4-WIRE ZONE VALVE WITH 120 VOLT MOTOR

## -E Units, Electric Backup Wiring

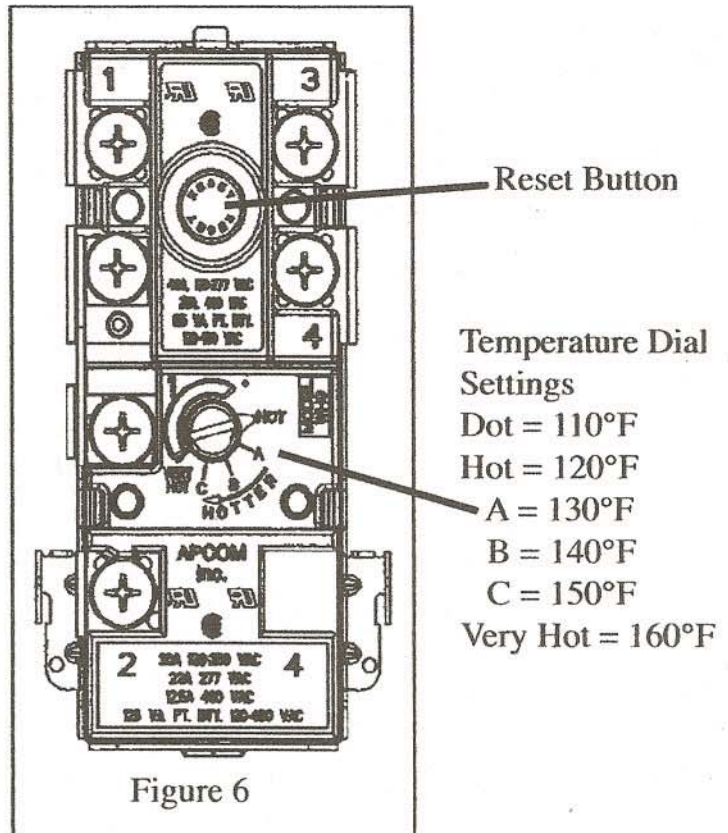
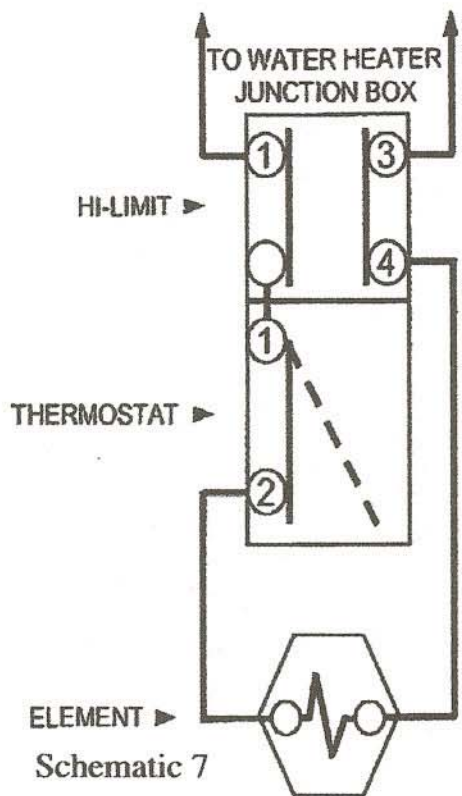

### **Solar Electric Tank Electrical Connections**

The solar electric hot water heater includes a 240VAC thermostat and a 4500 watt element. Refer to Schematic 7 for wiring detail.

#### **Connect Electric Heating Element**

Before any electrical connections are made, be sure that the water heater is full of water and that the valve in the cold water supply line is open. The solar water heater is supplied with a single electric heating element backup system. The thermostat incorporates a manual reset temperature-limiting device. Please refer to the TROUBLESHOOTING GUIDE section for manual reset operation. Turn off all power related to the heating system before proceeding with the electrical connections. Any and all wiring shall be sized and installed to satisfy the voltage and amperage used. The water heater must be well grounded. A green ground screw is provided at the electrical connection point for connecting a ground wire. All wiring shall be done in accordance with all applicable local and state codes.

#### **Adjusting The Temperature Dial On The Thermostat**

The minimum potable water temperature can be changed by adjusting the thermostat. Before any work is done on the water heater, disconnect all power to the water heater and heat source (solar collector) by opening the switch(s) at the main electrical circuit breaker or fuse box. Remove the cover and fold the insulation outward away from the control. Adjust the thermostat dial using a screwdriver until the minimum acceptable temperature is achieved. Rotate the temperature dial clockwise to increase water temperature. Rotate the thermostat dial counter-clockwise to decrease the temperature setting. See figure 6 for temperature settings. The thermostat has been factory preset to 120°F (49°C). Remember that lower temperature settings are more energy efficient. Replace the insulation making sure that the control is well covered and that the plastic terminal shield has not been displaced. Replace the access panel. The water heater is now ready for operation and the main switch can be closed.

## VI. Maintenance

The water heater is intended to provide many years of reliable service. Components, such as thermostats and relief valves, may be subject to failures that require service. Depending on the quality of the water supply, sediment and/or scale may coat the heating coil in the tank and reduce hot water recovery rate. Failure to use the correct procedures or parts can result in unsafe operation.

The owner should arrange to have the following inspections and simple maintenance procedures done at the suggested frequencies.

1. **Boiler and Domestic Water Piping (Annual)**  
Check all piping for signs of leakage at the joints, unions and shut-off valves. Repair as required.
2. **Temperature and Pressure Relief Valve (Annual)**
3. **Sediment (Annual except where harsh water quality may require more frequent service)**  
Depending on water conditions, a varying amount of sediment may collect in the tank. Levels requiring service are indicated by a small temperature difference between the boiler supply and return lines, and a reduced recovery rate. Repeated flushing usually clears such material. As a preventive measure, water should be drawn from the drain valve until it runs clear and the installation of a water filter should be considered.
4. **Scale (Annual)**  
Hard water may cause scale buildup on the outside of the heating coil inside the tank. A water softener will prevent this problem. Symptoms are identical to sediment buildup. If repeated flushing does not resolve the problem, chemical cleaning may be required. Proceed as follows:

### **Chemical cleaning of the heating coil**

1. To avoid water damage, shut off the cold water supply to the water heater.
2. Make a note of the temperature control setting on the water heater, and turn off the power to the water heater.
3. Relieve the water pressure in the tank by opening a hot water faucet. This will reduce the risk of scalding.
4. Remove the relief valve from the water heater.
5. Drain the water heater until the water is at a level equal to 3" above the thermostat well. This level will cover the coil and the thermostat.
6. Using a funnel, pour one gallon of commercial ice maker cleaning solution into the tank through the relief valve opening. Follow the instructions, cautions, and warnings supplied with the cleaning solution.
7. Set the water heater thermostat to its highest setting, turn on the power to the water heater, and allow the boiler to heat the water until the tank thermostat is satisfied. The boiler may cycle on its high limit several times during this period. If the tank thermostat is not satisfied after 45 minutes of boiler operation, turn the thermostat to its lowest setting.
8. Allow the heated solution to set in the tank 30 minutes.
9. Drain the tank completely using fittings and hoses, as required, to reach a drain.
10. Fill the water heater tank with fresh, cold, water and drain it completely. Repeat filling and draining at least three (3) times to flush all of the cleaning solution from the tank.
11. Reinstall the relief valve and the drain piping.
12. Open the cold water supply and fill the tank with water. Purge the air from the tank and the piping by opening the cold and hot water faucets in the house.
13. Return the temperature control to the setting noted in Step 2.

## VII. Troubleshooting

PROBLEM	CAUSE	SOLUTION
No hot water at faucets.	Boiler does not operate.  Circulator does not operate  Improper thermostat setting  Zone valve does not open  Electrical problem   Sediment and/or scale buildup    Clogged filter	Press reset button Check main cut-off switch Check fuses or breakers. Check power supply Check shaft coupling  Turn thermostat to a higher setting  Check power supply and valve.  Check fuses and replace. Check circuit breaker and reset. Check power supply  If boiler, circulator, and thermostat are operating properly, and the boiler is cycling on the high limit several times before the tank thermostat is satisfied, the coil may have a coating of sediment and/or scale. See chemical cleaning instructions.  Clean or replace filter.
Insufficient or runs out of hot water at the faucet.	Thermostat setting too low.  Undersized boiler with no priority to domestic water heating.  Peak draw of hot water is greater than the tank storage.  Sediment and/or scale buildup  Faulty water heater thermostat	Turn the thermostat to a higher setting.  Rewire for priority.  Determine peak usage and compare to tank volume.  Clean coil  Replace thermostat
Water at faucet too hot.	Thermostat set too high  Improper system plumbing   Improper wiring.	Lower thermostat setting.  Compare plumbing to installation guide. Inspect check valves.  Compare wiring to installation guide.
Boiler cycles more than 5 times per day in summer	Excessive demand  Faulty thermostat  Boiler high limit set too low  Sediment and or scale buildup	Reduce demand or consider larger boiler and/or water heater.  Replace thermostat  Increase boiler hi-limit setting  Clean coil.

**180 deg. F Boiler Supply  
IBR Rating Condition**



MODEL	30 and 40LOW				40				60			
	Boiler flow = 14 gpm				Boiler flow = 14 gpm				Boiler flow = 14 gpm			
BOILER OUTPUT (BTU/HR)	1st HOUR RATING (GAL/HR)		CONTINUOUS RATING (GAL/HR)		1st HOUR RATING (GAL/HR)		CONTINUOUS RATING (GAL/HR)		1st HOUR RATING (GAL/HR)		CONTINUOUS RATING (GAL/HR)	
	140 F	115 F	140 F	115 F	140 F	115 F	140 F	115 F	140 F	115 F	140 F	115 F
50,000	94	119	67	92	103	128	67	92	121	146	67	92
60,000	107	138	80	111	116	147	80	111	134	165	80	111
80,000	134	174	107	147	143	183	107	147	161	201	107	147
100,000	160	212	133	185	169	220	133	184	187	238	133	184
120,000	171	227	144	200	190	250	154	214	214	275	160	221
140,000	171	227	144	200	190	250	154	214	227	293	173	239
160,000	171	227	144	200	190	250	154	214	227	293	173	239

MODEL	60 LOW				80				115			
	Boiler flow = 14 gpm				Boiler flow = 14 gpm				Boiler flow = 14 gpm			
BOILER OUTPUT (BTU/HR)	1st HOUR RATING (GAL/HR)		CONTINUOUS RATING (GAL/HR)		1st HOUR RATING (GAL/HR)		CONTINUOUS RATING (GAL/HR)		1st HOUR RATING (GAL/HR)		CONTINUOUS RATING (GAL/HR)	
	140 F	115 F	140 F	115 F	140 F	115 F	140 F	115 F	140 F	115 F	140 F	115 F
50,000	121	146	67	92	139	164	67	92	170	195	67	92
60,000	134	165	80	111	152	183	80	111	183	214	80	111
80,000	161	201	107	147	179	219	107	147	210	250	107	147
100,000	187	238	133	184	205	256	133	184	236	287	133	184
120,000	208	268	154	214	232	293	160	221	263	324	160	221
140,000	208	268	154	214	239	303	167	231	289	360	186	257
160,000	208	268	154	214	239	303	167	231	289	360	186	257

**High Output Units - 80-HO and 115-HO - 21 gpm boiler flow**

MODEL	80-HO High Output				115-HO High Output			
	Boiler flow = 21 gpm				Boiler flow = 21 gpm			
BOILER OUTPUT (BTU/HR)	1st HOUR RATING (GAL/HR)		CONTINUOUS RATING (GAL/HR)		1st HOUR RATING (GAL/HR)		CONTINUOUS RATING (GAL/HR)	
	140 F	115 F	140 F	115 F	140 F	115 F	140 F	115 F
50,000	139	164	67	92	170	195	67	92
60,000	152	183	80	111	183	214	80	111
80,000	179	219	107	147	210	250	107	147
100,000	205	256	133	184	236	287	133	184
120,000	232	293	160	221	263	324	160	221
140,000	258	330	186	258	289	361	186	258
160,000	285	368	213	296	316	398	213	296
180,000	312	405	240	333	343	435	240	333
200,000	339	442	267	370	370	473	267	370
220,000	343	473	271	401	396	509	293	406
240,000	362	473	290	401	412	531	309	428
250,000	362	473	290	401	412	531	309	428

Heat-Flo, Inc.  
15 Megan Court, Uxbridge, MA 01569  
Tel: 508-278-2400 Fax: 508-278-2466  
www.heat-flo.com

**Heat-Flo, Inc.**  
**LIMITED WARRANTY**  
**Solar Hot Water Storage Tanks**  
**Models 115-D, 80-D, 60-D, 115-E, 80-E, 60-E, 115DE, 80DE, 60DE**

Your Solar Hot Water Storage Tank is protected by these Heat-Flo, Inc., (HFI), warranties. These warranties are applicable to original consumer purchases only.

**WARRANTY COVERAGE FOR RESIDENTIAL USAGE**

The warranties listed in this section shall apply to water heaters used in a residential setting by the original consumer purchasers only. A “residential setting” as used herein shall mean usage in a single-family dwelling in which the original consumer purchaser of the water heater resides on a **permanent basis**. “Residential setting shall also mean usage in a multiple family dwelling provided that the water heater services only one (1) dwelling in a multiple family dwelling.

**I. LIMITED ONE YEAR WARRANTY**

1. Control warranted by original manufacturer for a period of one (1) year.
2. HFI warrants the unit when properly registered with the factory at the time of purchase, as set forth below, to be free from defects in materials and workmanship. HFI will repair, or at its option, replace the unit.

**II. LIMITED WARRANTY ON STORAGE TANK/HEAT EXCHANGER ASSEMBLY**

HFI further warrants that the storage tank/heat exchanger assembly shall be free from leaks during normal use and service for one of two time periods:

1. **LIMITED FIVE YEAR WARRANTY** – for five years, as long as the original consumer purchaser owns the home (residence) in which the water heater is located.

**2. ADDITIONAL LIMITED LIFETIME WARRANTY**

HFI further warrants to the original user that for an additional period of ten (10) years from the date of expiration of the first five (5) years of this warranty set forth above, the tank assembly shall be free of leaks during normal use and service. In the event that a leak should develop and occur within this limited warranty period due to a defective material of workmanship, we will furnish a replacement water heater of the nearest comparable model current at the time of replacement. Replacement will be made upon payment by the original user of a percentage of the suggested retail price at the time of replacement as set forth in the following schedule:

Within 6 <sup>th</sup> through 7 <sup>th</sup>	- 60%
Within 8 <sup>th</sup> through 9 <sup>th</sup>	- 65%
Within 10 <sup>th</sup> through 11 <sup>th</sup>	- 70%
Within 12 <sup>th</sup> through 13 <sup>th</sup>	- 75%
14 <sup>th</sup> year and beyond	- 80%

**III. EXCLUSIONS AND LIMITATIONS**

This warranty extends to the original purchaser only (including first occupants of a new home), is non-transferable and shall apply only if:

1. The unit is correctly installed according to the installation instructions provided with the unit.
2. The unit is operated within the factory specified temperature limits, and at a water pressure not exceeding 150 psi.
3. Components of the water heater which are not defective, but must be replaced as a result of reasonable wear and tear.

4. Water Quality: The warranties extended by HFI are conditioned upon potable water with a Ph not to exceed 8.0 and not below 6.0. and / or chloride concentrations not to exceed 80 parts per million (ppm). HFI specifically disclaims liability of any kind resulting from or relating to potable water that does not match these characteristics.
5. Your home contains any type of water softening system, that the system is installed and maintained in accordance with the manufacturer's specifications.
6. Any failure or malfunction does result from improper or negligent operation, accident, abuse (including freezing), misuse, unauthorized alteration or improper repair or maintenance.
7. Any failure or malfunction does not result from failure to keep the unit full of potable water, free to circulate at all times; and the tank free of damaging water sediment or scale deposits.
8. The unit is used within the United States, its territories or possessions, or Canada.
9. The warranty does not cover labor costs, shipping charges, or deliver expenses, nor administrative fees incurred by the purchaser in removing or reinstalling the unit. Heat-Flo will not accept claims for labor costs incurred by the original consumer purchaser in removing or reinstalling the water heater.
10. Malfunctions resulting from, or repairs necessitated by, uses of the water heater for purposes other than that for which it was designed, or resulting from flood, fire, wind, or lightning.

### **OWNER'S RESPONSIBILITIES**

The owner or installer must:

1. Have the storage tank installed with a vacuum relief valve and a temperature and pressure relief valve in accordance with local, state, and federal codes and ordinances bearing the listing marks of the American Society of Mechanical Engineers (A.S.M.E).
2. Operate the storage assembly at a pressure below that shown on the rating plate on the pressure relief valve.
3. Keep the tank free of scale deposits.
4. **Make provisions so if the tank or any component part or connection should leak, the resulting flow of water will not cause damage to the area in which it is installed.**

The warranty hereunder does not apply to defects resulting from:

1. Freezing, excessive pressure, or leaks at water connections.
2. Failure of a component, control or component part other than a component part manufactured solely by HFI.
3. Any cause similar to the above, not resulting solely due to defective material and/or workmanship.
4. Water Quality: The warranties extended by HFI are conditioned upon potable water with a Ph not to exceed 8.0 and not below 6.0, and/ or chloride concentrations not to exceed 80 parts per million (ppm). HFI specifically disclaims liability of any kind resulting from or relating to potable water that does not match these characteristics.

### **LIMITATION OF WARRANTIES AND REMEDIES**

THE FOREGOING WARRANTIES ARE EXCLUSIVE AND ARE GIVEN AND ACCEPTED IN LIEU OF ANY AND ALL OTHER WARRANTIES, EXPRESS OR IMPLIED, INCLUDING WITHOUT LIMITATION THE IMPLIED WARRANTIES OF MERCHANTABILITY AND FITNESS FOR PARTICULAR PURPOSE, AND ANY OBLIGATION, LIABILITY, RIGHT, CLAIM, OR REMEDY IN CONTRACT OR TORT, WHETHER OR NOT ARISING FROM HEAT-FLO, INC.'S NEGLIGENCE, ACTUAL OR IMPUTED.

THE REMEDIES OF THE ORIGINAL CONSUMER PURCHASES SHALL BE LIMITED TO THOSE PROVIDED HEREIN TO THE EXCLUSION OF ANY OTHER REMEDIES INCLUDING WITHOUT LIMITATION, INCIDENTAL OR CONSEQUENTIAL DAMAGES INCLUDING, BUT NOT LIMITED TO, PROPERTY DAMAGE, LOST PROFIT, OR DAMAGES ALLEGED TO HAVE BEEN CAUSED BY ANY FAILURE OF HEAT-FLO, INC. TO MEET ANY OBLIGATION UNDER THIS AGREEMENT INCLUDING THE OBLIGATION TO REPAIR AND REPLACE SET FORTH ABOVE.

NO AGREEMENT VARYING OR EXTENDING THE FOREGOING WARRANTIES, REMEDIES, OR THIS LIMITATION WILL BE BINDING UPON HEAT-FLO, INC. UNLESS IN WRITING AND SIGNED BY A DULY AUTHORIZED OFFICER OF HEAT-FLO, INC.

THE WARRANTY STATED HEREIN IS NOT TRANSFERABLE AND SHALL BE FOR THE BENEFIT OF THE ORIGINAL CONSUMER PURCHASER OF A WATER HEATER ONLY.

These warranties give you specific legal rights, and you may also have other rights which vary from state to state. Some states do not allow the exclusion or limitation of incidental or consequential damages so this limitation or exclusion may not apply to you.

These are the only written warranties applicable to water heaters manufactured and sold by Heat-Flo, Inc. Heat-Flo, Inc. neither assumes nor authorizes anyone to assume for it any other obligation or liability in connection with said water heaters.

### **SERVICE REQUESTS**

FOR SERVICE UNDER THESE WARRANTIES CONTACT HEAT-FLO, INC., AT THIS ADDRESS:

Heat-Flo, Inc., P.O. Box 612, Uxbridge, MA 01569

At the time a claim is filed the original consumer purchaser must present a copy of the original sales receipt, and a deed, utility bill, or equivalent document evidencing both ownership of the water heater and installation in the dwelling or commercial property owned by the original consumer purchaser. With regard to claims made by original consumer purchasers of water heaters used in commercial settings as that term is defined herein, in no event shall notification of a service request be received later than five years from the date of purchase.

he obligations under this warranty apply only to domestic hot water tank installations where the warranty registration card has been completed by the owner of the site of the original installation and received by Heat-Flo in accordance with the terms and conditions herein set out and Heat-Flo has been notified of the alleged defect or deficiency within forty eight (48) hours from the occurrence or discovery of the alleged defect or deficiency.

Heat-Flo, Inc. reserves the right to change specifications or discontinue models without notice.

Bulletin WAR-071511SOLAR

# **Heat-Flo**

**HEATING PRODUCTS**

**Heat-Flo Inc., 15 Megan Court, Uxbridge, MA 01569      Bulletin IO-SOLAR-090111**  
Tel: 508-278-2400      FAX: 508-278-2400