

INSTALLATION, OPERATING, AND SERVICE INSTRUCTIONS

HEAT-FLO MULTI-ENERGY TANKS

SINGLE OR DUAL COIL UNITS

WITH OR WITHOUT ELECTRIC BACKUP

MODELS 60-D, 60-E, 60-DE, 80-D, 80-E, 80-DE,
115-D, 115-E, 115-DE



*Conforms to UL STD 174 NSF/ANSI 372
Certified to CAN/CSA STD C22.2 No. 110-94*



MAN_IO_HEAT-FLO MULTI-E REV G

For service or repairs to the water heater, call your heating contractor. Your water heater has been manufactured to provide years of service. In order to ensure proper service, the following information is provided to assist in enabling the installation, operation, and maintenance of this water heater. For your comfort, safety, and convenience, we recommend that this water heater be installed and serviced by a plumbing professional. When the installation is completed, keep this manual with the water heater. Information and specifications outlined in this manual are in effect at the time of the printing of this manual. Heat-flo reserves the right to discontinue, change specifications, or change systems at any time without notice.

Heat-flo, LLC.

15 Megan CT., P.O. Box 612 Uxbridge, MA 01569 USA

Safety Information

The following terms and symbols are used to bring attention to the presence of various risk levels, or to important information concerning product life.



Indicates presence of a hazard, which will cause severe personal injury, death, or substantial property damage if ignored.



Indicates the presence of a hazard, which can cause severe personal injury, death, or substantial property damage if ignored.



Indicates the presence of a hazard, which can cause minor personal injury or damage if ignored.



Indicates special instructions on installation, operation, or maintenance, which are important but not related to personal injury hazards.



Table of Contents

General Information	1
Pre-Installation Considerations	2
Dimensions and Capacities	3
Piping	6-11
Electrical	12-16
Operation	12
Important Scalding Information	12-13
Maintenance	17
Troubleshooting	18
Boiler Supply Ratings	19
Replacement Parts	19
Limited Warranty	19-21

IMPORTANT INFORMATION – READ CAREFULLY

NOTE: The equipment shall be installed in accordance with those installation regulations required in the area where the installation is to be made. These regulations shall be carefully followed in all cases. Authorities having jurisdiction shall be consulted before the installations are made.

All wiring on water heaters must be in accordance with the National Electrical Code (latest edition) and/or local regulations in the US, and in accordance with the Canadian Electrical Code (latest edition) and/or local regulations in Canada.

WARNING

Improper installation, adjustment, alteration, service or maintenance can cause property damage, personal injury, or loss of life. Read and understand the entire manual before attempting installation, start-up, operation, or service. Installation and service must be performed only by an experienced, skilled installer or service agency.

This water heater contains very hot water under high pressure. Do not unscrew any pipe fittings or attempt to disconnect any components of this water heater without positively assuring that the water is cool and has no pressure. Always wear protective clothing and equipment when installing, starting up or servicing this water heater to prevent scalding injuries. Do not rely on the pressure and temperature gauges to determine the temperature and pressure of the water heater. This water heater contains components that become very hot when the boiler is operating. Do not touch any components unless they are cool.

Failure to follow all instructions in the proper order can cause personal injury or death. Read all instructions, including all those contained in component manufacturers' manuals before installing, starting up, operating, maintaining, or servicing the water heater.

CAUTION

To reduce the risk of excessive pressures and temperatures in this water heater, install temperature and pressure protective equipment required by local codes but no less than a combination temperature relief valve certified by a nationally recognized testing laboratory that maintains periodic inspection of production of listed equipment or materials, as meeting the requirements for Relief Valves and Automatic Shutoff Devices for Hot Water Supply Systems, ANSI Z21.22-latest edition. This valve must be marked with a maximum set pressure not to exceed the marked working pressure of the water heater. Install the valve into an opening provide and marked for this purpose in the water heater and orient it or provide tubing so that any discharge from the valve will exit only within 6 inches above, or at any distance below, the structural floor, and cannot contact any live electrical part. The discharge opening must not be blocked or reduced in size under any circumstances.

These water heaters with single-wall stainless steel heat exchangers meet the Uniform Plumbing Code for installation in potable water systems provided that:

- The boiler water, including additives, is practically non-toxic, having a toxicity rating of class 1 as listed in Clinical Toxicology of Commercial Products, latest edition.
- The boiler water pressure is limited to maximum 30 psig by an approved safety or relief valve.
- The heat transfer medium is potable water or contains only substances that are recognized as safe by the U.S. Food and Drug Administration. (FDA)
- The pressure of the heat transfer medium is maintained less than the normal minimum operating pressure of the potable water system.

The maximum boiler water supply temperature to the indirect heat exchanger must not exceed 240 deg. F (115 deg. C).

Improper water quality will reduce the life of the water heater. Hard water, sediment, high or low PH and high levels of chlorides in the domestic water should be avoided. Be sure that PH levels fall between 6 and 8 and dissolved chlorides are less than 100 ppm. A filter must be used where sediment is greater than 5 microns in size in the water supplied to the unit. A water softening system is recommended for areas with hard water. In cases where water quality is unknown, a qualified water treatment expert should be consulted.

NOTICE: Damage to tanks caused by improper water quality is not covered under the warranty.

DANGER

DO NOT store or use gasoline or other flammable vapors or liquids in the vicinity of this or any other appliance. If you smell gas vapors, DO NOT try to operate any appliance - DO NOT touch any electrical switch or use any phone in the building. Immediately, call the gas supplier from a remotely located phone. Follow the gas supplier's instructions or if the supplier is unavailable, contact the fire department. Do not operate any appliance until the leakage is corrected.

DANGER

This water heater is supplied with an adjustable thermostat to control the water temperature. Hot water temperatures required for automatic dishwashers and laundry use can cause scald burns resulting in serious personal injury and/or death. The temperature at which injury occurs varies with the person's age and the time of exposure. The slower response time of disabled persons increases the hazard to them. **NEVER** allow small children to use a hot water tap or to draw their own bath water. **NEVER** leave a child or disabled person unattended in a bathtub or a shower.

IMPORTANT SAFETY INSTRUCTIONS

READ ALL INSTRUCTIONS BEFORE USING THIS WATER HEATER.

WARNING – When using electrical appliances, safety precautions should be taken to reduce the risks of fire, electric shock, and injury. These precautions include the following:

- This water heater must be grounded. Connect only to a properly grounded outlet. See “GROUNDING INSTRUCTIONS” found in Section IV.
- Install or locate this water heater only in accordance with the provided installation instructions.
- Use this water heater only for its intended use as described in this manual.
- Do not use an extension cord set with this water heater. If no outlet is available adjacent to the water heater, contact a qualified electrician to have one properly installed.
- As with any appliance, close supervision is necessary when used by children.
- Do not operate this water heater if it has a damaged cord or plug, if it is not working properly, or if it has been damaged or dropped.
- Your water heater should be installed and serviced only by qualified personnel. Contact nearest authorized service facility for examination, repair, or adjustment.

SAVE THESE INSTRUCTIONS

Pre-installation Considerations

Inspect shipment carefully for signs of damage. All equipment is carefully inspected and packed. Heat-flo’s responsibility ceases upon delivery of the water heater to the carrier in good condition. Any claims for damage or shortage must be filed immediately against the carrier by the consignee. No claims for variances or shortages will be allowed by the Manufacturer, unless they are presented within sixty days after receipt of the equipment.

Installation must conform to the requirements of the authority having jurisdiction. In the absence of such requirements, installation must conform to the National Plumbing Code and the National Electrical Code ANSI/NFPA No. 70 (current edition).

IMPORTANT CONSIDERATIONS BEFORE INSTALLATION

1. Water heater sizing:

Choose the water heater model based on the expected water usage for the given site. The average residence with one shower or more will require a Model 40 or larger. The Model 30 should only be considered for residences with minimal water demand, or for commercial applications without showers.

Factors that increase water demand dramatically include high flow shower heads, hot tubs, and the use of more than one shower at a time. Increase the tank size if these factors are present. Consult ASHRAE sizing guides and other references.

Dimensions, weights, ratings, and capacities are outlined in Tables 1, and 2 (Pg. 4).

2. Boiler sizing:

The water heater will provide the rated performance only if it is used with a boiler with a heating capacity of at least as much as the capacity ratings in Table 2. If the boiler has less capacity, the water heating output will be reduced. To determine performance with other boiler outputs, refer to the expanded capacity tables at www.heat-flo.com.

NOTICE

The maximum heat transfers through the coil (heat input) of the water heaters at 240 deg. F boiler supply temperature and 210 deg. F potable water temperature are as follows:

- Models 30 – 115 single coil units and models 60-D, 80-D, and 115-D dual coil units are less than 96,000 BTU/HR.
- Models 80-HO, 115-HO, 80-HO-C, and 115-HO-C high output units are less than 84,000 BTU/HR.
- Models 85-XHO and 115-XHO, the extra high output series, are less than 175,000 BTU/HR.

Potable water temperature is limited to below 210 deg. F and nominal water containing capacity is below 120 gallons for all indirect models.

Accordingly, per Part HLW-101.2, Section IV of the ASME Boiler and Pressure Vessel Code, all Heat-flo indirect water heater products are exempt from compliance with the code. **Check with local codes for applicability.**

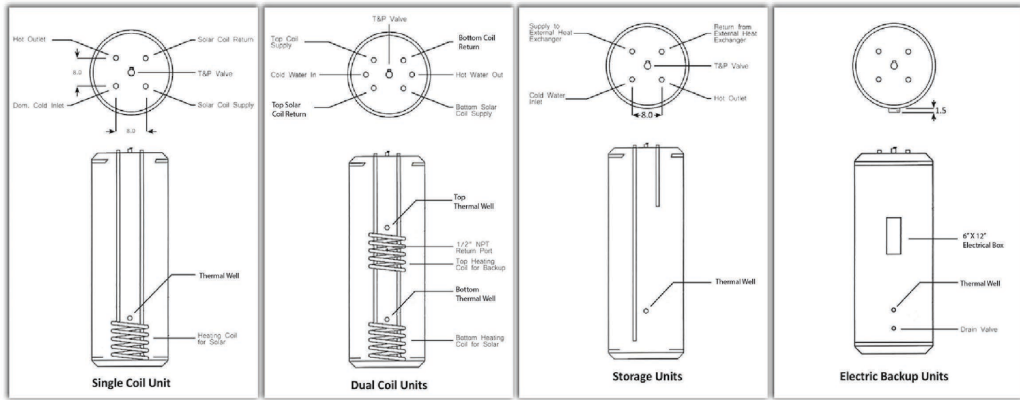

Dimensions and Capacities

Model	Storage Volume (Gal.)	Top Coil Heating Surface (Sq. Ft.)	Bottom Coil Heating Surface (Sq. Ft.)	Dimensions (Inches)		Pipe Connections	Max. Working Pressure (psi)	Approx. Shipping Wt. (Lbs.)
				(Ht.)	(Dia.)			
Single Coil - No Electric Backup								
HF-115	115	---	9.1	74.0	28.0	1" NPT	150	175
HF-80	80	---	8.2	56.0	28.0	1" NPT	150	140
HF-60	60	---	8.6	62.0	23.5	1" NPT	150	125
Single Coil with 4,500 Watt Electric Backup								
HF-115-E	115	---	9.1	74.0	28.0	1" NPT	150	180
HF-80-E	80	---	8.2	56.0	28.0	1" NPT	150	145
HF-60-E	60	---	8.6	62.0	23.5	1" NPT	150	135
Dual Coil - No Electric Backup								
HF-115-D	115	7.4	9.1	74.0	28.0	1" NPT	150	205
HF-80-D	80	7.4	8.2	56.0	28.0	1" NPT	150	175
HF-60-D	60	7.4	8.6	62.0	23.5	1" NPT	150	135
Dual Coil with 4,500 Watt Electric Backup								
HF-115-DE	115	7.4	9.1	74.0	28.0	1" NPT	150	215
HF-80-DE	80	7.4	8.2	56.0	28.0	1" NPT	150	185
HF-60-DE	60	7.4	8.6	62.0	23.5	1" NPT	150	175
Storage Only - No Coil, No Electric Backup								
HF-115-ST	115	---	No Coil Storage Only	74.0	28.0	1" NPT	150	170
HF-80-ST	80	---		56.0	28.0	1" NPT	150	130
HF-60-ST	60	---		62.0	23.5	1" NPT	150	115

TABLE 1

Heat Exchanger Coil Output

Model	Max. Recovery (Gal./Hr.)	Max. Recovery (Gal./Hr.)	Water Flow Through Coil (Gal./Min.)	Pressure Drop Through Coil (Ft. Water)
	Top Coil	Bottom Coil		
115-Gal. Units	190	214	10.0	3.9
80-Gal. Units	180	214	10.0	3.6
60-Gal. Units	185	214	10.0	3.5

Note: All ratings are based on 180 degree F boiler water supply and 50 degree F cold water inlet. In the interest of continuous improvement, specifications are subject to change without notice.

For All Units with 4,500 Watt Electric Backup

Model	First Hour Rating (Gal./HR.)		Continuous Rating (Gal./HR.)	
	140°	115°	140°	115°
115-Gal. Units	78.0	86.0	20.5	28.4
80-Gal. Units	60.0	68.0	20.5	28.4
60-Gal. Units	51.0	58.0	20.5	28.4

TABLE 2

3. Circulator sizing:

Refer to Table 2 (Pg. 4) for the flow through the water heater coil and the pressure drop. Calculate the pressure drop across all piping and fittings connected to the water heater zone. Be sure to include all zone valves, check valves, and shut-off valves. It is recommended that the water heater zone be piped with 1" pipe around the entire loop on typical residential sites.

SYSTEM ZONE CONTROL

The water heater must be installed as a separate zone from the space heating system. The water heating zone's piping and circulator must be sized for the minimum flow rate with all the zones in use and a maximum flow with only the water heater in use. The best method is to use a separate circulator for the water heater.

The three most common systems are:

1. Zone Circulators – The space heating zones use a circulator for each zone, and the water heater is controlled with an additional circulator.
2. Hybrid System – The space heating zones use zone valves for each zone, and the water heater is controlled with an additional circulator.
3. Zone Valves – The space heating zones use zone valves for each zone, and the water heater is controlled with an additional zone valve. Select a valve with a low pressure drop and assure minimum flow with adequate pipe sizing.

PRIORITY OR NON-PRIORITY FOR HOT WATER

Option 1: Priority

The demand for space heating is interrupted until the hot water demand is satisfied. This option provides the maximum delivery of hot water.

Priority is recommended when:

- a. The boiler output is less than 100,000 Btu per hour. Or,
- b. The boiler output required to satisfy the hot water demand is more than 50% of the boiler output needed to satisfy the space heating demand. Or,
- c. When an interruption in space heating can be tolerated during long domestic hot water draws.

In most cases the delay in space heating will not be noticed because of the rapid recovery of the water heater. It must be recognized however that certain water heater malfunctions, such as a failed thermostat or circulator, could delay space heating indefinitely.

Option 2: Non-Priority:

The boiler output is divided between space heating and water heating. Heating of domestic hot water can be reduced during simultaneous space and water heating demands. The amount of reduction depends on the boiler output, the number of space heating zones calling, and the amount of boiler water flow split between the space heating and zones and the water heater zone.

LOCATING THE WATER HEATER

The water heater should be located in an area where water leakage from the tank or connections will not result in damage to areas adjacent to the water heater or to lower floors of the structure. When such a location cannot be avoided, a suitable drain pan must be installed under the water heater, and the drain pan must be connected to a drain. The drain pan depth must be suitable for draining and collecting water. The piping to drain must be at least 3/4" diameter and be pitched for proper drainage.

The water heater should be installed as close to the boiler as is practical for easy access for service. The unit is designed for installation on combustible flooring and in alcoves, closets, etc.

The minimum clearances from combustible surfaces are:

Bottom	0"
Left, Right, and Rear Sides	1"
Front	1"
Top	6"

The minimum clearances for service are:

Bottom	0"
Left, Right, and Rear Sides	3"
Front	30"
Top	6"

ADDITIONAL RECOMMENDED COMPONENTS

1. **Shut-Off Valves:** Allows the isolation of the water heater from the boiler system during service.
2. **Unions:** Allows for easy locating or removal.
3. **Vacuum Breaker:** Protects the water heater from collapse if a hot tank is valved off to service other components in the system.
4. **Thermal expansion tank:** If the water heater is installed in a closed water supply system, such as a system having a back flow preventer, a check valve, or a pressure reducing valve in the cold-water supply line, the installation of a thermal expansion tank is required.

REMOVING THE EXISTING DOMESTIC WATER HEATING SYSTEM

External Tankless Heater

Disconnect all lines to the boiler and plug the boiler fittings. Disconnect the external heater from the boiler piping, and the domestic piping systems.

Internal Tankless Heaters

Disconnect the domestic piping. Do not plug the cold water or the hot water fittings in the internal tankless coil. Leave the coil in the boiler with the cold and hot water fittings open to prevent pressure build-up in the coil.

NOTICE

For California installation this water heater must be braced, anchored, or strapped to avoid falling or moving during an earthquake. See instructions for correct installation procedures. Instructions may be obtained from California Office of the State Architect.

WATER QUALITY

Improper water quality will reduce the expected life of the water heater. Hard water, sediment, high or low Ph, and high levels of chlorides in the domestic water should be avoided. Sediment and hard water will eventually coat the heating coil inside the water heater and reduce the rate of hot water production and may eventually cause a failure. High or low Ph and/or high chloride concentrations will cause corrosion and eventually failure. A filter is strongly recommended where sediment is present in the water. A water softening system is recommended for areas with hard water. In an area where the water quality is not known, a water quality test should be performed.

⚠ WARNING

Do not operate the Heat-flo water heaters in areas where the Ph is above 8.0 or below 6.0, and/or with chloride concentrations greater than 100 parts per million (ppm). Heat-flo's standard warranty does not cover problems caused by improper water Ph or excessive levels of chlorides.

NOTICE

Damage to tanks caused by improper water quality is not covered under the warranty.

PIPING

DOMESTIC WATER PIPING (See Figure 1, Pg. 10)

1. Drain the domestic water system.
 - Shut off the cold-water supply at the main shutoff valve.
 - Open one or more faucets to relieve the pressure.
 - Open the system drain, leaving the faucets open.
2. Position the new water heater in its final location.
3. Connect the cold-water supply piping.
 - Install piping onto cold inlet connection.
 - Connect to cold water supply connection using a union, a heat trap, a shut-off valve, a vacuum breaker, an expansion tank (where required), and a filter (recommended to prevent sediment buildup).

NOTICE

If installing on a city supply, a properly sized thermal expansion tank is required and should be installed in accordance with the product installation manual.

If a water heater is installed in a closed water supply system, such as one having a backflow preventer in the cold-water supply, a check valve in the cold-water supply, or a pressure reducing valve in the cold-water supply means shall be provided to control thermal expansion.

The appliance, when installed, must be grounded in accordance with the local codes, or in the absence of local codes, with the National Electrical Code, ANSI/NFPA 70.

⚠ WARNING

If this product is connected to a cold-water supply line that has a check valve, a backflow preventer, a pressure reducing valve, or a check valve in the water meter, it is a requirement that a properly sized thermal expansion tank be installed in the cold-water inlet line. *There will be no warranty on applications where there is no pressure control.*

4. Connect the domestic hot water piping.
 - Install piping onto hot water supply connection using a union, a heat trap, and a shut off valve.
 - Pipe the relief valve discharge so that the discharge from the valve will exit only within 6 inches above, or at any distance below, the structural floor and so that it cannot contact any live electrical part. The discharge opening must not be blocked or reduced in size under any circumstances.

⚠ WARNING

Install a discharge line so that water discharged from the temperature and pressure relief valve will exit within six (6) inches above, or any distance below, the structural floor and cannot contact any live electrical part. The discharge line is to be installed to allow for complete drainage of both the temperature and pressure relief valve and the discharge line. The discharge opening must not be subjected to blockage or freezing.

DO NOT thread, plug, or cap the discharge line. It is recommended that a minimum clearance of four (4) inches be provided on the side of the water heater for servicing and maintenance of the combination temperature and pressure relief valve.

Do not place a valve between the combination temperature and pressure relief valve and the tank!

5. Fill the water heater.
 - Open all faucets to allow air to purge from the tank and piping. Remove screens on faucets.
 - Open domestic hot water shut-off valve.
 - Open cold-water inlet shut-off valve.
 - Purge all of the air from the domestic water system. Allow water to run so the tank is completely purged of any debris. Run the water long enough to change at least five tank volume changes.
 - Close all faucets. Reinstall all of the screens in the faucets.
 - Check the system for leaks. Repair as required.

BOILER WATER PIPING (Refer to Figures 2, 3 on Pg. 11)

1. Determine where the boiler, the space heating, and the water heater connections should be made based on the type of piping system that is either in place or is to be installed for a new hydronic system installation. See Figure 2 (Boiler Water Piping with Zone Circulators) and Figure 3 (Boiler Water Piping with Zone Valves).
2. It is recommended that 1" pipe and 1" zone valves be used on the water heater zone.

ZONE CIRCULATOR SYSTEM

For space heating systems that use Zone Circulators, refer to Figure 2 on pg. 11. The water heater connection labeled "BOILER SUPPLY" should be piped to the boiler supply piping after the air purger and before the space heating takeoffs. Mount the water heater circulator as close to the water heater as possible, and make sure the flow arrow points toward the water heater. The use of shut-off valves is recommended for future service convenience.

The water heater connection labeled "BOILER RETURN" should be piped to the boiler return piping as close to the boiler as possible and after any flow control or check valves in the space heating return piping. The use of a union and a shut-off valve is recommended. The use of a check valve is required to prevent back flow through the water heater during operation of the space heating system.

ZONE VALVE SYSTEM

For a space heating system that uses Zone Valves, refer to Figure 3 on pg. 11. The water heater connection labeled "BOILER SUPPLY" should be piped to the boiler supply piping after the air purger and before the space heating circulator. Mount the water heater circulator as close to the water heater as possible, and make sure the flow arrow points toward the water heater. The use of a shut-off valve is recommended for future service convenience.

The water heater connection labeled "BOILER RETURN" should be piped to the boiler return piping as close to the boiler as possible and after any flow control or check valves in the space heating return piping. The use of a union and a shut-off valve is recommended. The use of a check valve is required to prevent back flow through the water heater during operation of the space heating system.

Indirect Piping

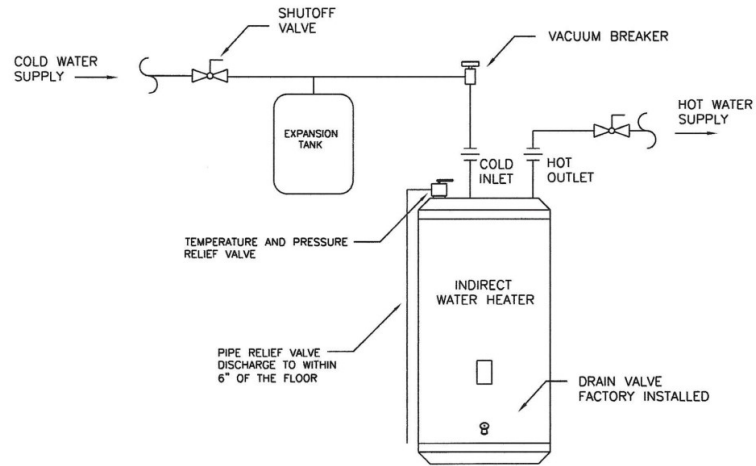

FIGURE 1
DOMESTIC WATER PIPING

NOTE: FIGURES 1, 2, AND 3 ARE MEANT TO ILLUSTRATE SYSTEM PIPING ONLY. THE INSTALLER IS RESPONSIBLE FOR CONFORMING TO THE LOCAL CODES. IN MASSACHUSETTS, YOU MUST INSTALL A VACUUM RELIEF VALVE PER 24B CMR. SEE LOCAL CODE REQUIREMENTS.

Indirect Piping

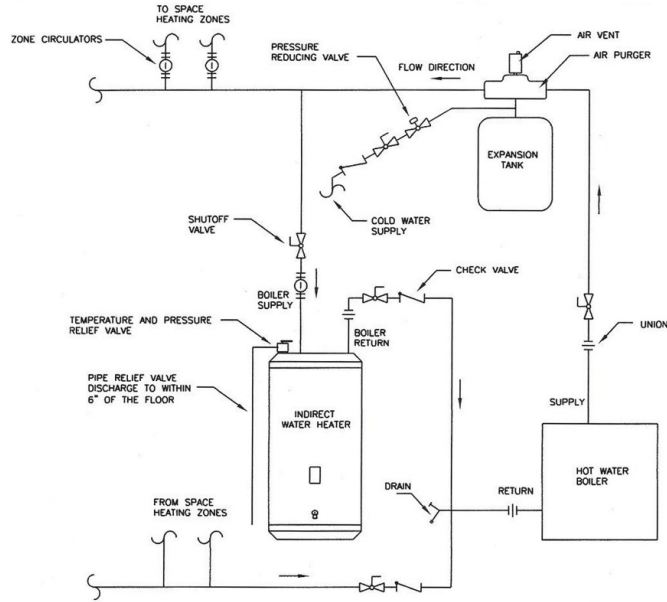

FIGURE 2 – BOILER WATER PIPING WITH ZONE CIRCULATORS

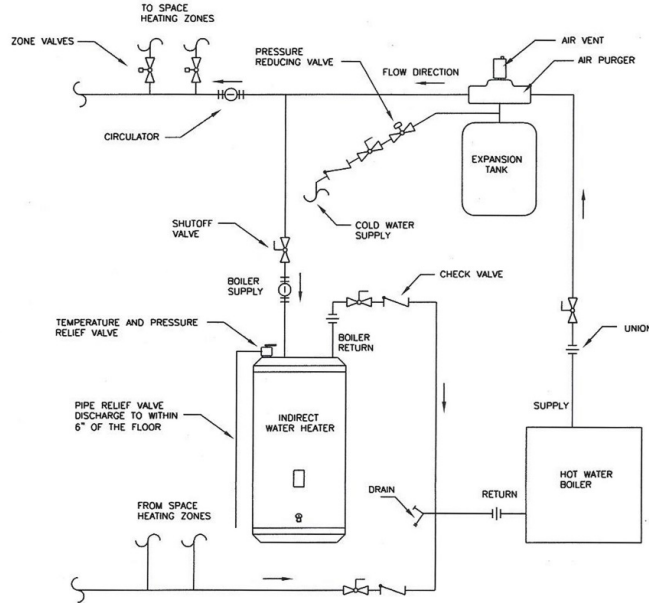
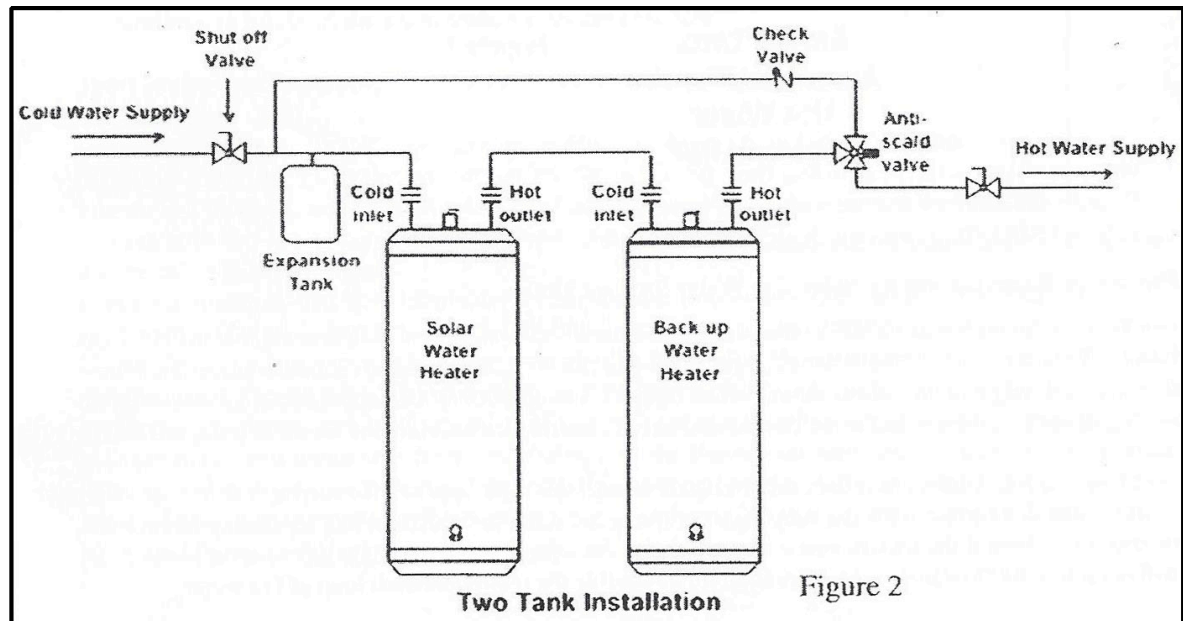
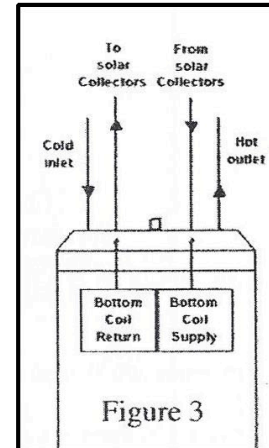
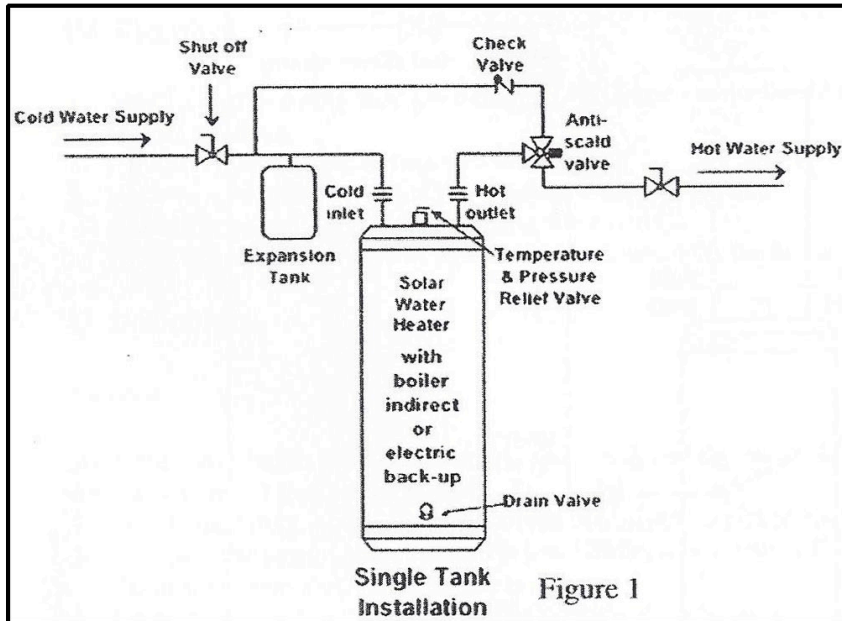
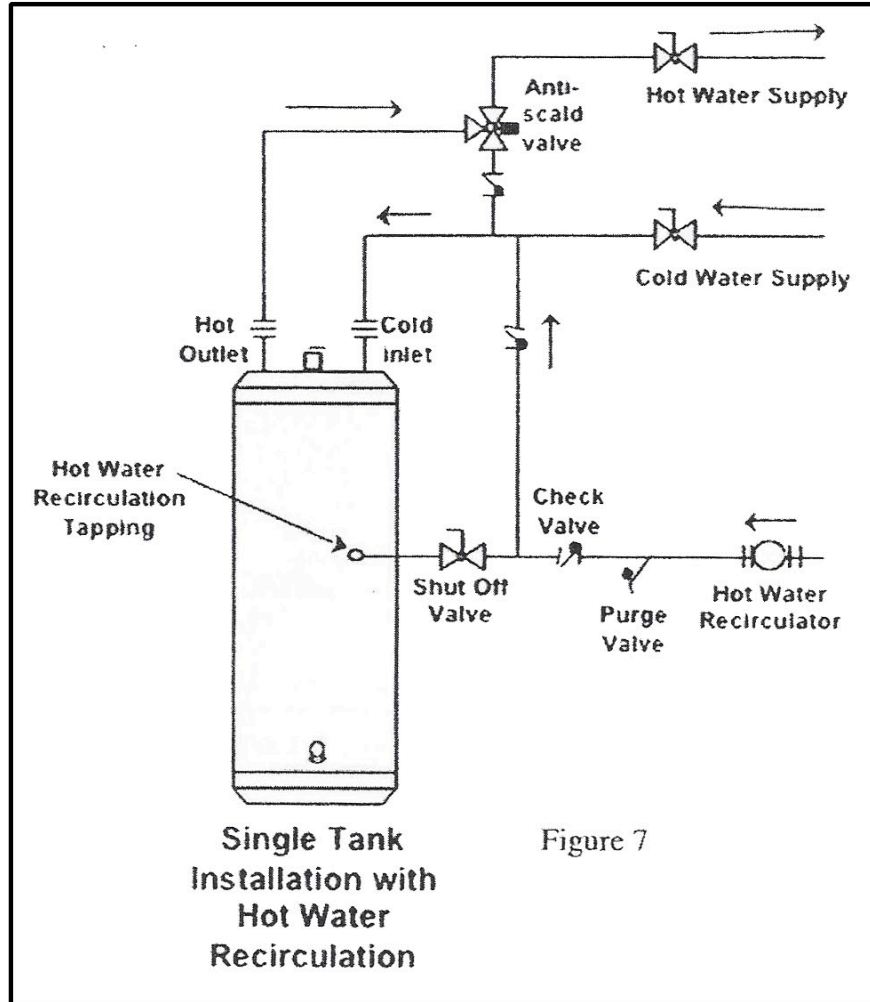

FIGURE 3 – BOILER WATER PIPING WITH ZONE VALVES

Solar Piping



Solar Piping



HOT WATER RECIRCULATION

Hot Water Recirculation for Multi-Energy Tanks

Hot water recirculation is for the continuous circulation of hot water for instant hot water at the hot water faucets. With the multi-energy tanks, tapplings are provided for the hot water recirculation return. See Figure 7. The location of the tapping will not allow for the mixing of back-up heated hot water (boiler indirect or electric element) into the lower solar heated section of the tank.

When an anti-scald device is installed, it is critical to feed the cold supply of the mixing valve with the return of recirculated hot water. This is important to keep the hot water recirculation loop operating through the mixing valve even if the tank temperatures are above the mixing valve setting. Otherwise, the mixing valve will not allow the flow of hot water through it and disable the recirculation loop of hot water.

ELECTRICAL

1. Install electric wiring and grounding in accordance with the National Electrical code (latest edition) and/or local regulations in the US, and in accordance with the Canadian Electrical Code (latest edition), and/or local regulations in Canada.
2. All water heaters are supplied with a thermostat.
 - Refer to schematics 1, 2 and 3 for separate circulator wiring.
 - Refer to schematics 4, 5 and 6 for zone valve wiring.
 - Other options include using one of the many good zone controls that are on the market.

---Reference should be made to the Installation Manual for the boiler as well.---

OPERATION

STARTUP

After the water heater has been plumbed and wired and the boiler water piping is purged of air, the water heater is ready to be started.

1. Follow the boiler installation instructions to place the boiler in operation.
2. The tank thermostat is factory pre-set to 125 degrees F and will call for heat if the water in the tank is lower than that (125 deg. F).
3. On a call for heat, the tank thermostat contacts close to start the water heater zone circulator and the boiler.
4. After the tank has reached the temperature setting, the tank thermostat opens and de-energizes the circulator and the boiler. If there is a call for space heating, the boiler will continue to run until the room thermostats are satisfied.

WARNING - **SCALDING!**

This water heater can deliver scalding temperature water at any faucet in the system. Be careful when using hot water to avoid scalding injury. By setting the thermostat on this water heater to obtain an increased water temperature, you create the potential for scald injury. To protect against injury, you should install an ASSE approved mixing valve (a device to limit the temperature of water to protect against scald injury via mixing hot and cold-water supply) in the water system. This valve will reduce point of discharge temperature in branch supply lines. Such valves are available from a local plumbing supplier. Please consult with a plumbing professional.

SCALD RELATIONSHIPS

The tank thermostat controls the maximum water temperature in the water heater. If it is set too high, the resulting hot water can cause painful scalding with possible serious and permanent injury. The temperature at which this occurs varies with a person's age, and the length of time in contact with the hot water. The slower response time of infants, older, or handicapped people increases the hazard for them.

WATER TEMPERATURE ADJUSTMENT

It is recommended that the thermostat be set for the lowest possible temperature that satisfies your needs. This will also provide you with the lowest energy consumption and cost.

Check the water temperature at a hot water faucet soon after the tank thermostat has satisfied, and the circulator and the boiler have turned off. Adjust as needed.

Lowering the thermostat setting will not have an immediate effect on the water temperature because the stored water will have to be used and the thermostat must go through the cycle of heating cold water and satisfying at the new, lower temperature. Additional temperature checks should follow the completion of a heating cycle. Further adjustments may be required after you have used the water heater.

The table below details the approximate relationship of water temperature and time with regard to scald injury and may be used as a guide in determining the safest water temperature for your applications.

APPROXIMATE TIME/ TEMPERATURE RELATIONSHIPS IN SCALDS	
120°F (52°C)	More than 5 Minutes
125°F (52°C)	1-1/2 to 2 Minutes
130°F (54°C)	About 30 Seconds
135°F (57°C)	About 10 Seconds
140°F (60°C)	Less than 5 Seconds
145°F (63°C)	Less than 3 Seconds
150°F (66°C)	About 1-1/2 Seconds
155°F (68°C)	About 1 Seconds

The scald label shown to the right can be found on all Heat-flo Indirect Water Heaters and Storage tanks. Take note and use caution when adjusting the temperature settings with your water system. Be sure to always feel the water before bathing or showering, especially when drawing a bath for an infant or elder.

⚠ DANGER



Water temperature over 125°F can cause severe burns instantly or death from scalds.

Children, disabled and elderly are at highest risk of being scalded.

See instruction manual before setting temperature at water heater.

Feel water before bathing or showering.

Temperature limiting valves are available, see manual.

– Important **WARNING** information on Pg. 18. –

Indirect Wiring

SEPARATE CIRCULATOR WIRING

Honeywell Relay R4222D1013 with Q633A receptacle

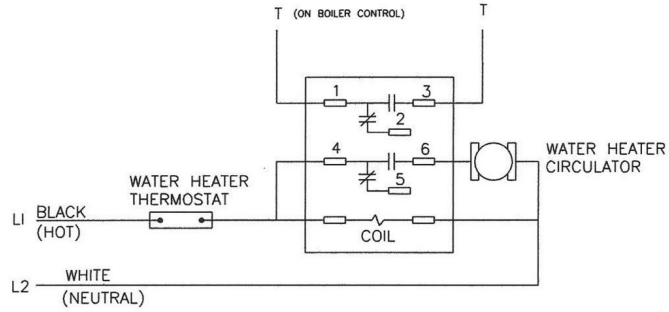

SCHEMATIC 1
24 VOLT "T-T" WIRING

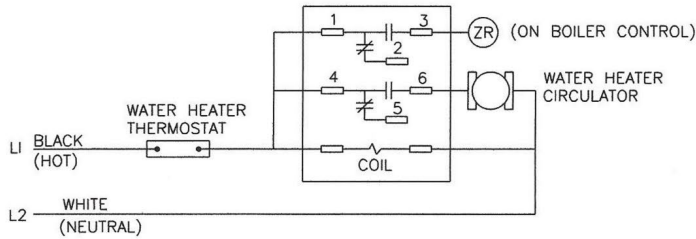

WHEN NO "ZR" TERMINAL IS AVAILABLE
WIRE TO THE SUPPLY SIDE OF THE HI LIMIT

SCHEMATIC 2
120 VOLT - ZR TERMINAL

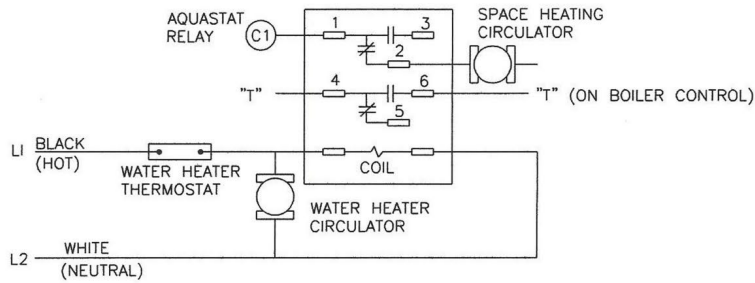

SCHEMATIC 3
PRIORITY WITH CIRCULATORS

Indirect Wiring

ZONE VALVE WIRING

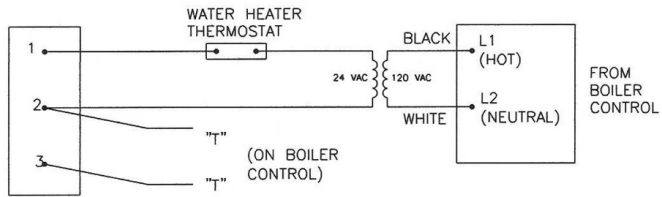

SCHMATIC 4
3-WIRE ZONE VALVE

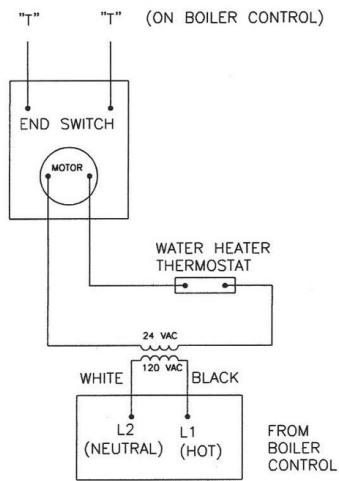

SCHMATIC 5
4-WIRE ZONE VALVE WITH 24 VOLT MOTOR

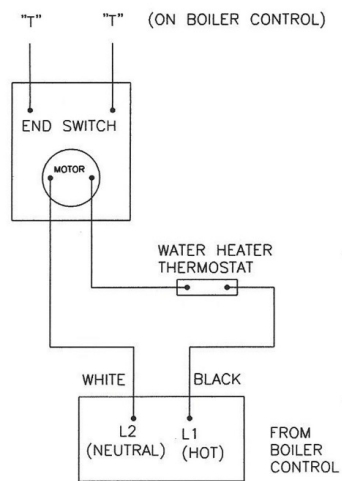

SCHMATIC 6
4-WIRE ZONE VALVE WITH 120 VOLT MOTOR

-E Units, Electric Backup Wiring

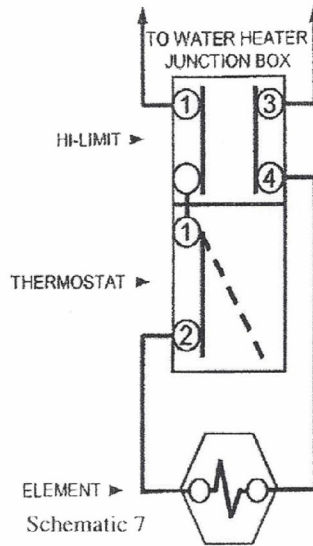

SOLAR ELECTRIC TANK

Electrical Connections

The Multi-Energy hot water heater includes a 240-Volt thermostat and a 4500-watt element. Refer to *Schematic 7* for wiring detail.

Connect Electric Heating Element

Before any electrical connections are made, be sure that the water heater is full of water and that the valve in the cold-water supply line is open. The multi-energy water heater is supplied with a single electric heating element backup system. The thermostat incorporates a manual reset temperature-limiting device. Please refer to the *Troubleshooting Guide* on pg. 22 for manual reset operation. Turn off all power related to the heating system before proceeding with the electrical connections. Any and all wiring shall be sized and installed to satisfy the voltage and amperage used. The water heater must be grounded. A green ground-nut is provided at the electrical connection point for connecting a ground wire. All wiring shall be done in accordance with all applicable local and state codes.

Adjusting the Temperature Dial on the Thermostat

The minimum potable water temperature can be changed by adjusting the thermostat. Before any work is done on the water heater, disconnect all power to the water heater and heat source (solar collector) by opening the switch(es) at the main electrical circuit breaker or fuse box. Remove the cover and fold the insulation outward, away from the control. Adjust the thermostat dial using a screwdriver until the minimum acceptable temperature is achieved. Rotate the temperature dial clockwise to increase water temperature. Rotate the thermostat-dial counter-clockwise to decrease the temperature setting. See *Figure 6* for temperature settings.

The thermostat has been factory-set to 120° F (49° C). Remember that lower temperature settings are more energy efficient. Replace the insulation to assure that the control is well covered and that the plastic terminal shield has not been displaced. Replace the access panel. The water heater is now ready for operation and the main switch can be closed.

▲ WARNING

It is the responsibility of the installing contractor to see that all controls are correctly installed and are operating properly when the installation is complete.

DO NOT operate the water heater with jumpered or absent controls or safety devices.

DO NOT tamper with or alter the water heater and/ or controls.

DO NOT operate the water heater if any external part has been under water. Immediately call a qualified service technician to inspect the appliance and to replace any part of the control system that is or had been under water.

DO NOT install this water heater on carpeting. This water heater is suitable for installation on combustible flooring.

DO NOT operate this water heater without first being certain it is filled with water.

MAINTENANCE

The water heater is intended to provide many years of reliable service. Components, such as thermostats and relief valves, may be subject to failures that require service. Depending on the quality of the water supply, sediment and/or scale may coat the heating coil in the tank and reduce hot water recovery rate. Failure to use the correct procedures or parts can result in unsafe operation.

The owner should arrange to have the following inspections and simple maintenance procedures done at the suggested frequencies.

1. Boiler and Domestic Water Piping (Annual)
 - Check all piping for signs of leakage at the joints, unions and shut-off valves. Repair as required.
2. Temperature and Pressure Relief Valve (Annual)
 - The temperature and pressure relief valve should be checked to ensure that it is in operating condition. To check the relief valve, lift the lever at the end of the valve several times. The valve should seat properly and operate freely. If water does not flow, remove and inspect for obstructions or corrosion. Replace with a new valve of the recommended capacity as necessary. Do not attempt to repair the valve, as this could result in improper operation and a tank explosion. In areas with poor water conditions, it may be necessary to inspect the temperature and pressure relief valve more often than once a year.

CAUTION

Before manually operating the valve, make sure that a drain line has been attached to the valve to direct the discharge to an open drain. Failure to take this precaution could mean contact with extremely hot water discharging from the valve during this checking operation.

If the temperature and pressure relief valve on the heater discharges periodically or continuously, it may be due to thermal expansion of water in a closed water supply system, or it may be due to a faulty relief valve. Thermal expansion is the normal response of water when it is heated. In a closed system, thermal expansion will cause the system pressure to build until the relief valve actuation pressure is equaled. Then the relief valve will open, allowing some water to escape, slightly lowering the pressure. Contact your water supplier or local plumbing inspector on how to control this situation.

ABOVE ALL, DO NOT PLUG THE TEMPERATURE AND PRESSURE RELIEF VALVE. THIS IS NOT A SOLUTION AND CAN CREATE A HAZARDOUS SITUATION.

3. Sediment (Annual except where harsh water quality may require more frequent service)
 - Depending on water conditions, a varying amount of sediment may collect in the tank. Levels requiring service are indicated by a small temperature difference between the boiler supply and return lines, and a reduced recovery rate. Repeated flushing usually clears such material. As a preventive measure, water should be drawn from the drain valve until it runs clear, and the installation of a water filter should be considered.
4. Scale (Annual)
 - Hard water may cause scale buildup on the outside of the heating coil inside the tank. Symptoms are identical to sediment buildup. If repeated flushing does not resolve the problem, chemical cleaning may be required. Proceed as follows:

CHEMICAL CLEANING OF THE HEATING COIL

1. To avoid water damage, shut off the cold-water supply to the water heater.
2. Make a note of the temperature control setting on the water heater and turn off the power to the water heater.
3. Relieve the water pressure in the tank by opening a hot water faucet. This will reduce the risk of scalding.
4. Remove the relief valve from the water heater.
5. Drain the water heater until the water is at a level equal to 3" above the thermostat well. This level will cover the coil and the thermostat.
6. Using a funnel, pour one gallon of commercial ice maker cleaning solution into the tank through the relief valve opening. Follow the instructions, cautions, and warnings supplied with the cleaning solution.
7. Turn on the power to the water heater and allow the boiler to heat the water until the tank thermostat is satisfied. The boiler may cycle on its high limit several times during this period. If the tank thermostat is not satisfied after 45 minutes of boiler operation, turn the thermostat to its lowest setting.
8. Allow the heated solution to set in the tank 30 minutes.
9. Drain the tank completely using fittings and hoses, as required, to reach a drain.
10. Fill the water heater tank with fresh, cold, water and drain it completely. Repeat filling and draining at least three (3) times to flush all of the cleaning solution from the tank.
11. Reinstall the relief valve and the drain piping.
12. Open the cold-water supply and fill the tank with water. Purge the air from the tank and the piping by opening the cold and hot water faucets in the house.

TROUBLESHOOTING

PROBLEM	CAUSE	SOLUTION
No hot water at faucets.	<ul style="list-style-type: none"> • Boiler does not operate • Circulator does not operate • Improper thermostat setting • Zone valve does not open • Electrical problem • Sediment and/or scale buildup • Clogged filter 	<p>Press reset button. Check main cut-off switch. Check fuses or breakers. Check power supply. Check shaft coupling. Turn thermostat to a higher setting. Check power supply and valve.</p> <p>Check fuses and replace.</p> <p>Check circuit breaker and reset.</p> <p>Check power supply.</p> <p>If boiler, circulator, and thermostat are operating properly, and the boiler is cycling on the high limit several times before the tank thermostat is satisfied, the coil may have a coating of sediment and/or scale. See chemical cleaning instructions (Pg. 16).</p> <p>Clean or replace filter.</p>
Insufficient/ runs out of hot water at the faucet.	<ul style="list-style-type: none"> • Thermostat setting too low. • Undersized boiler with no priority to domestic water heating. • Peak draw of hot water is greater than the tank storage. • Sediment and/or scale buildup • Faulty water heater thermostat 	<p>Turn the thermostat to a higher setting.</p> <p>Rewire for priority.</p> <p>Determine peak usage and compare to tank volume.</p> <p>Clean coil.</p> <p>Replace thermostat.</p>
Water at faucet too hot.	<ul style="list-style-type: none"> • Thermostat set to high • Improper system plumbing • Improper wiring 	<p>Lower thermostat setting.</p> <p>Compare plumbing to installation guide.</p> <p>Inspect check valves.</p> <p>Compare wiring to installation guide.</p>
Boiler cycles more than 5 times per day in summer.	<ul style="list-style-type: none"> • Excessive demand • Faulty thermostat • Boiler high limit set to low • Sediment and or scale buildup 	<p>Reduce demand or consider larger boiler and/or water heater.</p> <p>Replace thermostat.</p> <p>Increase boiler hi-limit setting.</p> <p>Clean coil.</p>

	Description	Heat-flo Part Number
1	TEMPERATURE AND PRESSURE RELIEF VALVE – CASH ACME NCLX-8	VALVE-75-CASH ACME-NCLX-8
2	TEMPERATURE AND PRESSURE RELIEF VALVE – CASH ACME FVMX-8C	VALVE-75-CASH ACME-FVMX-8C
3	THERMAL WELL	THERMAL WELL
4	PENN A-19 THERMAL CONTROL	THERMAL CONTROL
5	¾” NPT DRAIN VALVE	VALVE-DRAIN

Multi-Energy Unit Coils			
Model	HF-60-D	HF-80-D	HF-115-D
Top Coil =	HF-30	HF-30	HF-40
Bottom Coil =	HF-60	HF-80	HF-115
For More Data Refer to Heat Exchanger Coil Ratings on the Website www.heat-flo.com			



Heat-flo, LLC.
LIMITED WARRANTY
MULTI-ENERGY TANKS
HF60-D HF80-D HF115-D
HF60-DE HF80-DE HF115-DE

ME

Your tank is protected by these Heat-flo, LLC., (HFL), warranties. These warranties are applicable to original consumer purchases only.

WARRANTY COVERAGE FOR RESIDENTIAL USAGE

The warranties listed in this section shall apply to tanks used in a residential setting by the original consumer purchasers only. A “residential setting” as used herein shall mean usage in a single-family dwelling in which the original consumer purchaser of the tank resides on a **permanent basis**. “Residential setting shall also mean usage in a multiple family dwelling provided that the tank services only one (1) dwelling in a multiple family dwelling.

LIMITED WARRANTY ON TANK

HFL warrants that the tank shall be free from leaks due to material or manufacturing defects during normal use and service for one of two time periods:

- LIMITED FIVE-YEAR WARRANTY** – HFL warrants that the tank shall be free from leaks due to material or manufacturing defects for five years, as long as the original consumer purchaser owns the home (residence) in which the tank is located.

- ADDITIONAL LIMITED WARRANTY**

HFL further warrants to the original user that for an additional period of ten (10) years from the date of expiration of the first five (5) years of this warranty set forth above, the tank assembly shall be free of leaks during normal use and service. In the event that a leak should develop and occur within this limited warranty period due to a defective material or workmanship, we will furnish a replacement tank of the nearest comparable model current at the time of replacement. Replacement will be made upon payment by the original user of a percentage of the suggested retail price at the time of replacement as set forth in the following schedule:

Within 6 th through 7 th	- 60%
Within 8 th through 9 th	- 65%
Within 10 th through 11 th	- 70%
Within 12 th through 13 th	- 75%
14 th year and beyond	- 80%

WARRANTY ON THE OPERATING CONTROL

The operating control (if applicable) is warranted by original manufacturer for a period of one (1) year from installation date. If no documentation is available as proof of installation, the warranty on the operating control will commence on the date of manufacture of the associated tank.



ME

WARRANTY COVERAGE FOR COMMERCIAL USAGE

The warranties listed in this section shall apply to Heat-flo, LLC. tanks used in a commercial setting by the original commercial purchasers only. A “commercial setting” as used herein shall mean any usage not falling within the above definition of a “residential setting”. A Heat-flo, LLC. tank shall also be deemed used in a “commercial setting” if at any time it is operated at a temperature above 150 degrees Fahrenheit.

Heat-lo, Inc. warrants that it will repair or replace, at its option, without charge, any defect or malfunctioning of the tank within the warranty period set forth below.

During the first through fifth years after the original date of delivery to the original commercial purchaser, Heat-flo, LLC. will repair or replace, at its option, without charge, any tank having a defect or malfunction due to a manufacturing defect that results in a water leak from the outer jacket, inner tank, or heat exchanger as a result of normal use and service. It is expressly agreed between Heat-flo, LLC. and the original consumer purchaser that the repair or replacement is the exclusive and sole remedy of the original consumer purchaser.

If Heat-flo, LLC. is unable to repair or replace the tank so as to conform with this warranty after a reasonable number of attempts, then Heat-flo, LLC. will provide, at its option, either a replacement product, or a full refund of the purchase price. These remedies are the exclusive remedies of the original consumer purchaser

EXCLUSIONS AND LIMITATIONS -- RESIDENTIAL AND COMMERCIAL INSTALLATIONS

This warranty extends to the original purchaser only (including first occupants of a new home), is non-transferable and shall apply only if:

1. The unit is correctly installed according to the installation instructions provided with the unit.
2. The unit is operated within the factory specified temperature limits, and at a water pressure not exceeding 150 psi.
3. Components of the tank which are not defective but must be replaced as a result of reasonable wear and tear.
4. Water Quality: The warranties extended by HFL are conditioned upon potable water with a PH not to exceed 8.0 and not below 6.0. and / or chloride concentrations not to exceed 100 parts per million (ppm). HFL specifically disclaims liability of any kind resulting from or relating to potable water that does not match these characteristics.
5. Any failure or malfunction resulting from improper or negligent operation, accident, abuse (including freezing), misuse, unauthorized alteration or improper repair or maintenance.
6. Any failure or malfunction resulting from failure to keep the unit full of potable water, free to circulate at all times, and the tank free of damaging water sediment or scale deposits.
7. The unit is used within the United States, its territories or possessions, or Canada.
8. The warranty does not cover labor costs, shipping charges, or deliver expenses, nor administrative fees incurred by the purchaser in removing or reinstalling the unit. Heat-flo will not accept claims for labor costs incurred by the original consumer purchaser in removing or reinstalling the tank.
9. Malfunctions resulting from, or repairs necessitated by, uses of the tank for purposes other than that for which it was designed, or resulting from flood, fire, wind, or lightning.

OWNER’S RESPONSIBILITIES

ME

The owner or installer must:

1. Have the tank installed with a properly sized potable expansion tank, a vacuum relief valve and a temperature and pressure relief valve in accordance with local, state, and federal codes and ordinances bearing the listing marks of the American Society of Mechanical Engineers (A.S.M.E).
2. Operate the tank at a pressure below that shown on the rating plate on the pressure relief valve.
3. Keep the tank free of scale deposits.
4. Make provisions so if the tank or any component part or connection should leak, the resulting flow of water will not cause damage to the area in which it is installed.

The warranty hereunder does not apply to defects resulting from:

1. Freezing, excessive pressure, or leaks at water connections.
2. Failure of a component, control, or component part other than a component part manufactured solely by HFL.
3. Any cause similar to the above, not resulting solely due to defective material and/or workmanship.

LIMITATION OF WARRANTIES AND REMEDIES

THE FOREGOING WARRANTIES ARE EXCLUSIVE AND ARE GIVEN AND ACCEPTED IN LIEU OF ANY AND ALL OTHER WARRANTIES, EXPRESS OR IMPLIED, INCLUDING WITHOUT LIMITATION THE IMPLIED WARRANTIES OF MERCHANTABILITY AND FITNESS FOR PARTICULAR PURPOSE, AND ANY OBLIGATION, LIABILITY, RIGHT, CLAIM, OR REMEDY IN CONTRACT OR TORT, WHETHER OR NOT ARISING FROM HEAT-FLO, LLC.'S NEGLIGENCE, ACTUAL OR IMPUTED.

THE REMEDIES OF THE ORIGINAL CONSUMER PURCHASER SHALL BE LIMITED TO THOSE PROVIDED HEREIN TO THE EXCLUSION OF ANY OTHER REMEDIES INCLUDING WITHOUT LIMITATION, INCIDENTAL OR CONSEQUENTIAL DAMAGES INCLUDING, BUT NOT LIMITED TO, PROPERTY DAMAGE, LOST PROFIT, OR DAMAGES ALLEGED TO HAVE BEEN CAUSED BY ANY FAILURE OF HEAT-FLO, LLC. TO MEET ANY OBLIGATION UNDER THIS AGREEMENT INCLUDING THE OBLIGATION TO REPAIR AND REPLACE SET FORTH ABOVE.

NO AGREEMENT VARYING OR EXTENDING THE FOREGOING WARRANTIES, REMEDIES, OR THIS LIMITATION WILL BE BINDING UPON HEAT-FLO, LLC. UNLESS IN WRITING AND SIGNED BY A DULY AUTHORIZED OFFICER OF HEAT-FLO, LLC.

THE WARRANTY STATED HEREIN IS NOT TRANSFERABLE AND SHALL BE FOR THE BENEFIT OF THE ORIGINAL CONSUMER PURCHASER OF A TANK ONLY. THE WARRANTY IS LIMITED TO ONE REPLACEMENT PER SITE.

These warranties give you specific legal rights, and you may also have other rights which may vary from state to state. Some states do not allow the exclusion or limitation of incidental or consequential damages so this limitation or exclusion may not apply to you.

These are the only written warranties applicable to tanks manufactured and sold by Heat-flo, LLC. Heat-flo, LLC. neither assumes nor authorizes anyone to assume for it any other obligation or liability in connection with said tanks.

SERVICE REQUESTS

FOR SERVICE UNDER THESE WARRANTIES CONTACT HEAT-FLO, LLC., AT THIS ADDRESS:
Heat-flo, LLC., P.O. Box 612, Uxbridge, MA 01569 USA

At the time a claim is filed the original consumer purchaser must present a copy of the original sales receipt, and a deed, utility bill, or equivalent document evidencing both ownership of the tank and installation in the dwelling or commercial property owned by the original consumer purchaser. With regard to claims made by original consumer purchasers of tanks used in commercial settings as that term is defined herein, in no event shall notification of a service request be received later than five years from the date of purchase.

The obligations under this warranty apply only to tank installations where the warranty registration card has been completed by the owner of the site of the original installation and received by Heat-flo in accordance with the terms and conditions herein set out and Heat-flo has been notified of the alleged defect or deficiency within forty-eight (48) hours from the occurrence or discovery of the alleged defect or deficiency. Heat-flo, LLC. reserves the right to change specifications or discontinue models without notice.

Bulletin WAR-ME-08142024



Heat-flo, LLC.

15 Megan Ct., P.O. Box 612, Uxbridge, MA 01569, USA
| Tel: (508)-278-2400 | Email: sales@heat-flo.com | Fax: (508)-278-2466 |

www.heat-flo.com

